



MS200™

Installation Guide - WeatherTight Warranty Details

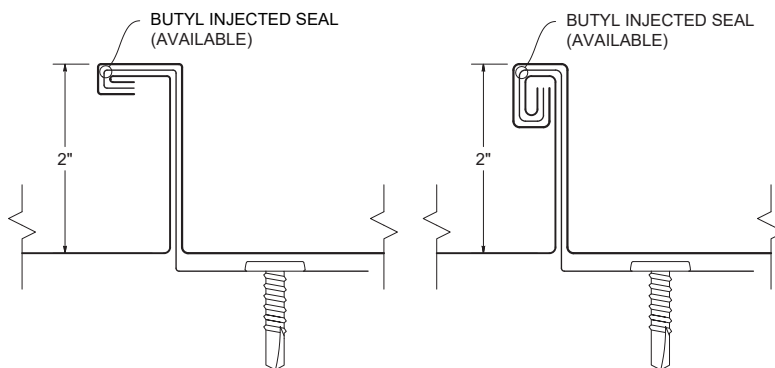
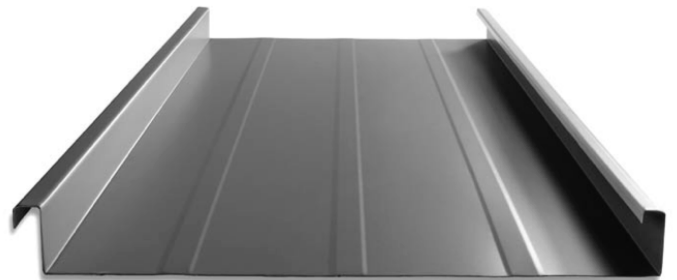
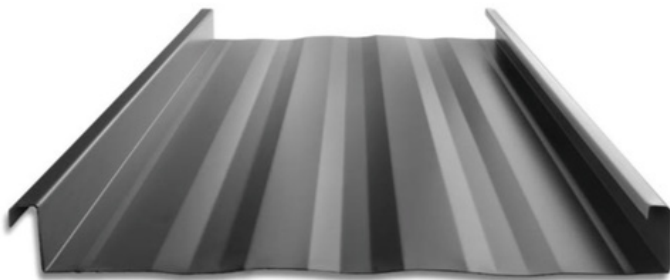

Table of Contents

Panel Specifications 2-3

Floating Panel Clip 4

Notes To Designer/Installer 5-7

Taylor Delivery Fleet 8

Delivery, Will Call & Loading 9

Standard Eave 10

Hook Eave 11

Gutter/Hook Eave 12

Standard Ridge 13

Vented Ridge 14

End Dam Attachment 15

Valley Flashing 16

Valley Flashing – Low Pitch 17

Standard Gable 18

Alternate Gable 19

Sidewall 20

Peak Flashing (R.E.C.) 21

Vented Peak Flashing (R.E.C.) 22

Pitch Change 23

Endwall 24

Vented Endwall 25

Saw Cut Endwall 26

Curb Back Pan/Cricket Isometric Details 27-29

Curb Sidewall 30

Curb Endwall 31

Curb/Pan Cricket 32

Eave to Gable Transition 33-35

Pipe Penetration – on Plate 36



Pipe Penetration – on Rib 37-38

Pipe Penetration – on Pan 39

Flashing Selection 40-43



KEY FEATURES

- 12", 14", 16", & 18" options available
- 24 & 22 gauge Tru-Gauge™ and .032" Aluminum
- Floating clip system: allows for expansion/contraction of panels in longer lengths
- 2" Mechanical seam rib, 90° or 180°: Factory notching available
- Factory injected Butyl sealant
- Structural panel that will span up to 5'
- Concealed fasteners: fasteners cannot leak
- Manufactured in Riverside CA, Sacramento CA & Salem OR
-  ICC EVALUATION SERVICE™ ICC-ESR #5046 with CBC-CRC Supplement
- FM Global Class #4471 Approved
-  - Code compliance UL Evaluation Report UL ER 25913-01
- UL Construction No. 90, 176, 180, 238, 238 A-C, 435, 435 A, 437, 449, 451, 452, 487, 506, & 506 A-C
- UL 580 Class 90 Wind Uplift, UL 790 Class A Fire rated and UL 2218 Class 4 Impact (hail) rated
- Dade PA 201-94 Class 90 Impact, 140 MPH Wind Uplift
- FM I-75 (60" o.c.)
FM I-120 (24" o.c.)
- ASTM E283 - Air infiltration (walls)
ASTM E331 - Water infiltration (walls)
ASTM E1592 - Structural uniform static air pressure
ASTM E1646 - Water infiltration (roof)
ASTM E1680 - Air infiltration (roof)
ASTM E2140 - Water test for full immersion hydrostatic roof systems
- Weather tightness warranty available
(Contact TMP representative for details)
- 1/2:12 minimum pitch recommended
(For lower pitches, please inquire)
- Standard panel lengths 5' to 60' - not notched
Standard panel lengths 1' to 60' - notched
(For longer panel lengths, please inquire)
- On-site roll forming available for long lengths
- Panel options: Striations, Accent Ribs, and Flat Pan
- Retro-fit systems available



- Prevents crowning
- No visible screws required
- Sharp, professional appearance

PANEL PROFILES



ICC-ESR #5046

12", 14", 16", 18" coverage options

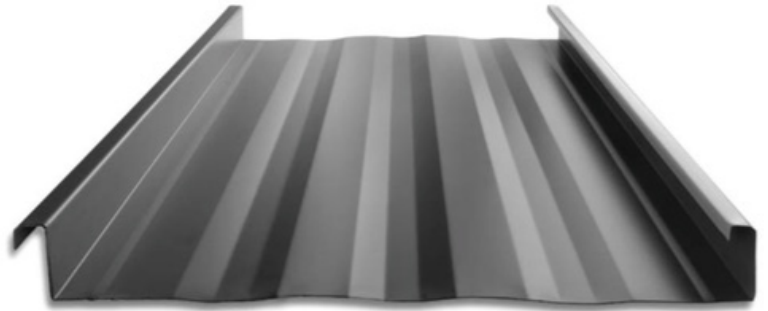

STRIATIONS

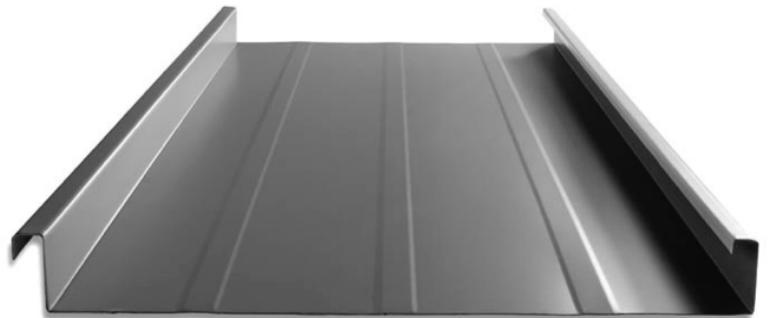

ACCENT RIBS

2 Accent ribs for 12" & 14" panel
3 Accent ribs for 16" & 18" panel

90° SEAM DETAIL

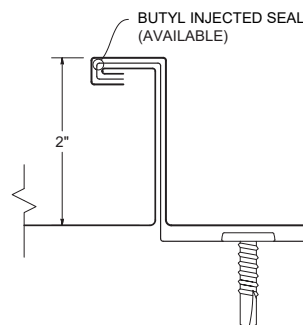

180° SEAM DETAIL

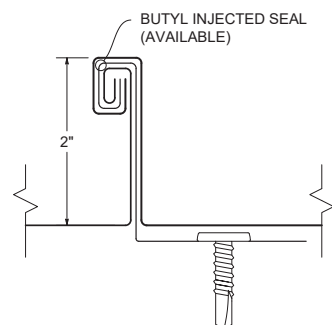

180 degree seams are not considered an architectural detail. The detail improves the weather tightness and wind uplift capabilities of the panel system, but will show stress and waviness in the seam. The detail is recommended for slopes less than 3/12, roof areas not easily viewed from the ground, and for high wind areas. For additional information, contact a TMP representative and DI Seamers for support and information about the proper use of seaming tools.

MATERIAL SPECIFICATIONS

- 24 gauge Kynar 500® Painted Steel
.0236" (Thickness prior to painting)
Galvanized G-90 or AZ-50
- 24 gauge bare Zincolume® Plus AZ-55
(No finish warranty – 25 yr. perforation warranty)
- ▲ 22 gauge Kynar 500® Painted Steel
.029" (Thickness prior to painting)
- ◆ .032" Kynar 500® Painted Aluminum
- 22 gauge Rusteel Plus™ (A606)
- 16 and 20 ounce Copper
(Please inquire)
- Kynar 500® and substrate testing data available
(See website)
- "Oil canning" is an inherent characteristic of roof and wall products, and not a defect, which is not a cause for panel rejection

KEY FEATURES

- 21 Standard Colors, 5 Metallic Colors and 4 Specialized Colors
- Kynar 500® Paint System - the ultimate in exterior durability and color retention
- "Cool" color pigments are specially designed to reflect infrared light, reducing heat gain to dwelling, and conform with ENERGY STAR® criteria
- Superior Quality, two coat, 70% resin finish, applied at a 1 mil. thickness
- 40 year residential paint warranty
- 20 and 30 year commercial paint warranty: Contact TMP for warranty specifications

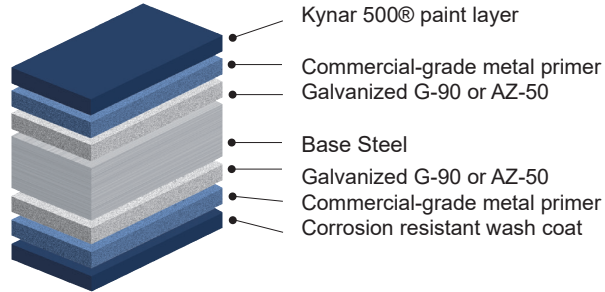

40-Year Residential / 20 and 30 Year Commercial Manufacturer's Limited Warranty

STANDARD COOL KYNAR 500® COLORS

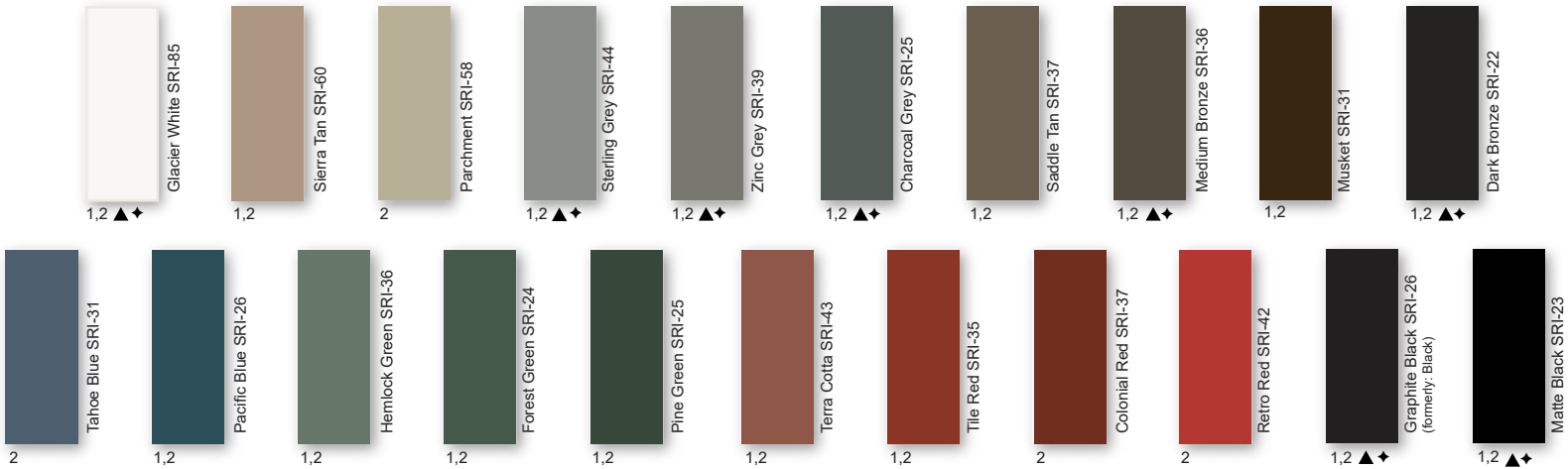

PREMIUM METALLIC COOL KYNAR® COLORS

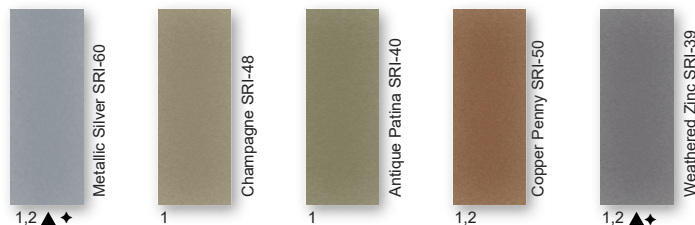

SPECIALIZED MATERIAL

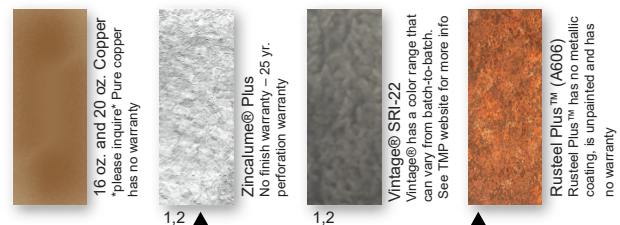

These printed chips provide a close representation of the colors.

Metal samples are available upon request. Coatings are low gloss 10-15% sheen. SRI = Solar Reflective Index. SRI values listed above are in accordance with ASTM E 1980 and are based on actual testing.***Oil canning is not a cause for material rejection***

Standard Panels				
Width	Gauge	Color	LBS SQFT	LBS LF
14"	24	1	1.36	1.65
18"	24	2	1.28	1.93
18"	22	▲	1.61	2.42
16"	.032 Alum	◆	0.60	0.90



**Taylor Metal Products
MS-200™ - UL 90 Floating Clip
18 ga. Base/22 ga. Top**

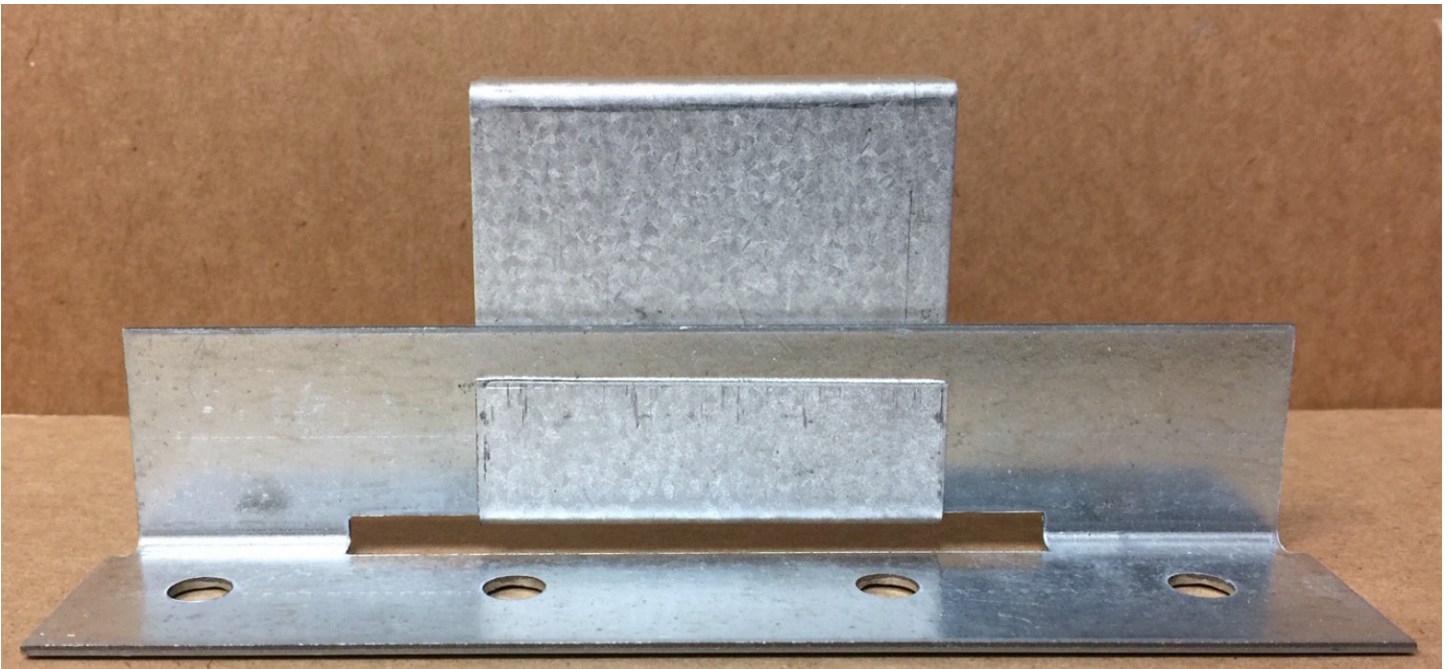

**UL 580 Class 90 Wind Uplift Rated
UL Class A Fire Rated**

Notes to Designer/Installer

Taylor Metal Products is providing the following details as an aid in design. The details in this guide are not inclusive to all design situations. The designer/installer is responsible for modifications and should take into consideration all aspects of the project including climate conditions, such as, snow and wind, as well as, building code requirements, building design, building usage and maintenance requirements.

Installation should be performed only by qualified installers familiar with metal roofing systems and industry standards. For details not shown in this guide, refer to the Sheet Metal and Air Conditioning Contractors National Association (SMACNA) architectural sheet metal manual for proper design. For manufacturer's weather tightness warranties – all details must be preapproved by Taylor Metal Products technical representative.

The Standard gauge for all products in this guide is 24 gauge and the standard finish is Kynar 500®. We recommend specifying all flashings be the same gauge, color, and finish as the panels to insure long-term durability and color match.

Substrates

Details in the manual are all shown over solid substrate. **MS-200™** can be used over spaced purlins. For solid substrate, **Taylor Metal Products** recommends 15/16" plywood or 22 ga. metal decking.

Underlayment

For roofs with pitches below 3:12, High Temp Ice and Water shield underlayment must be installed across the entire surface (projects with manufacturer's weathertightness warranties require the TMP private label product). For pitches steeper than (or equal to) 3:12, High Temp Ice and Water is necessary at all perimeter locations, eave, ridge, valley, hips, sidewall, endwall, prow and penetrations. The remaining of the roof's field areas can then be covered with approved synthetic felt. If local codes or specifications require a Class A fire rated assembly, Polystick XFR or Titanium FR (both products are distributed by TMP) must be installed over the entire roof with combustible decks.

Follow manufactures instructions carefully for all underlayment installation.

Drag Load Requirements

All panels must be pinned at one end to resist the drag load caused by snow loads, live loads, and the weight of the panel. Drag load is a function of roof slope, actual load and length of panels. Contact **Taylor Metal Products** for specific drag load requirements.

Ventilation/Insulation

It is the responsibility of the designer to determine the material types needed to control condensation and to insulate and ventilate the roof system. Applications over rigid insulation may require blocking for solid attachment and framing the perimeter for installation of perimeter flashings.

Oil Canning

Flat metal surfaces will display waviness commonly referred to as “oil canning.” Oil canning is caused by a variety of conditions. Steel mill tolerances, variations in or uneven substrates and roofing underlayments. Oil canning is a characteristic of metal roofing, not a defect and is not a cause for rejection. **Taylor Metal Products** offers **MS-200™** with striations or accent ribs to help minimize oil canning.

Thermal Movement

The Panels and the flashings must be allowed to expand and contract, especially with longer length panels. The panel may need to have a slight gap where the panel hooks the offset cleat to allow for thermal movement of the panels.

Snow Design

The following details do not address all conditions for snow environments. Consult with the designers, engineers, and others for acceptable details to accommodate your project and climate conditions. When possible gutters, valleys, pitch changes or other penetrations should be minimized in snow areas.

All roof penetrations should be located as close to the ridge or “pin point” top of roof. Snow country requires special designs for valleys to accommodate accumulation of snow and ice from uphill panels. Roof design should be considered in snow areas. Roof design should help resist the melting and freezing of snow and ice.

A fit for purpose roof design has the greatest impact on maintaining a damage free roof system in snow areas. Please contact a Taylor Metal Products representative for assistance in detail designs and appropriate panel selection for specific climate and building conditions.

Handling / Storage & Safety

Handle materials with care when off-loading or moving materials to avoid damage to panels or flashings. Long panels may require two or more pick-up points, properly spaced to avoid damaging panels. Plan ahead; contact Taylor Metal Products for recommendations on handling/hoisting long panels.

Store the panels, flashings and accessories in a dry, well ventilated area, off the ground. If covering, allow ventilation around panels. Elevate one end of bundle to allow drainage of wet materials.

Wear clean, soft-soled shoes when walking on roofing panels to avoid damage to the painted finish.

Take care that sand, gravel, dirt, etc. sticking to your shoes is not carried onto the roof, scratching or otherwise damaging the finish on the roofing material. Walking on asphalt impregnated felt paper, especially on a hot day, can cause the asphalt to stick to your shoes and be tracked on to the roofing material.

Take care when painting to avoid getting over spray on the roofing material. Remember that wind can carry paint particles some distance. Over spray can cause the finish of the roofing material to look dull and may void your warranty.

Secure materials, especially when leaving the site, on the ground or roof to prevent winds from moving the materials. Wind-blown materials may cause damage to the material, property or persons.

Always use proper safety equipment and attire to minimize risk of cuts or other injuries.

Do not walk on panels that have not been completely installed.

Do not walk on major ribs of panels.

Metal roofs that are wet or dusty can be extremely slippery. Wear soft soled shoes and a safety harness to minimize risk of falling.

Avoid installing metal panels in windy conditions.

Safety considerations are the responsibility of the installer and his crew. Be sure to and **use common sense** generally accepted safety practices when installing roofing materials.

Taylor Delivery Fleet



Delivery Fleet

Taylor Metal Products prides itself with quick lead times delivered with our fleet of semi trucks. Our fleet of trucks are owned and operated by TMP. All of our drivers are Taylor Metal Products employees, so when your truck rolls in to deliver, you are dealing with Taylor Metal Products.

Expect consistent and exceptional service with short leadtimes. The inhouse fleet allows for efficient and cost-effective delivery.



Mounted on the rear of our truck's trailer, the trailer-mounted "Piggy-Back" forklift will accompany you right to your place of use, opening up unprecedented possibilities in terms of transportation. It can travel sideways, carrying panels up to 40' long, allowing delivery in locations that would typically be considered impossible to reach.

Save time and effort while avoiding potential loading and transport issues; have experienced TMP personnel deliver and unload your order.



Delivery

We will make every attempt to deliver material to the desired location. We may be unable to gain access on tight corners or steep terrain. If the site is deemed inaccessible by our driver, the customer may choose an alternate delivery site within a reasonable proximity. If we are unable to make the delivery, additional charges may be assessed.

The customer is responsible for:

- Determining adequate access for delivery ahead of time.
- Meeting the delivery at the agreed upon time.
- Providing adequate resources (1-4 people as needed) for off loading materials.
- **A charge of \$100 per hour may be added for deliveries that go beyond their allotted time.**
- Checking the shipment at the time of delivery.
- Verifying material quantities against the shipping/packing list.
- Noting any damage or discrepancies upon the paper work at the time of delivery and notifying Taylor Metal Products within 48 hours of delivery.

Delivery times are usually scheduled one day in advance. Taylor Metal Products will make every effort to make the delivery at the scheduled time. Please be aware that there may be conditions beyond our control such as traffic, mechanical failures, road closures, etc. which may affect our schedule.

Will Call & Loading

Flatbed trailers and trucks are best suited to transport metal roofing materials. These can be loaded from the side with a forklift and tied down in a safe and secure manner.

We are not able to load materials onto vehicles and/or trailers which are not suitable or may be hazardous to load. Please be aware that if we find a vehicle to be inappropriate, we reserve the right to refuse to load your order.

Unacceptable examples include: boat trailers, vans, buses, motor homes, campers and box trailers. Pickup racks which do not have sufficient supports for the weight or are not long enough to support bundles are also unacceptable.

Taylor Metal Products is not responsible to tie down loads nor do we provide any tie down materials. Please bring tie downs to secure your load (string or twine are **not** acceptable for this purpose).

Consider having your order delivered on one of our trucks with a piggy back forklift.



Standard Eave

STANDARD EAVE DETAIL

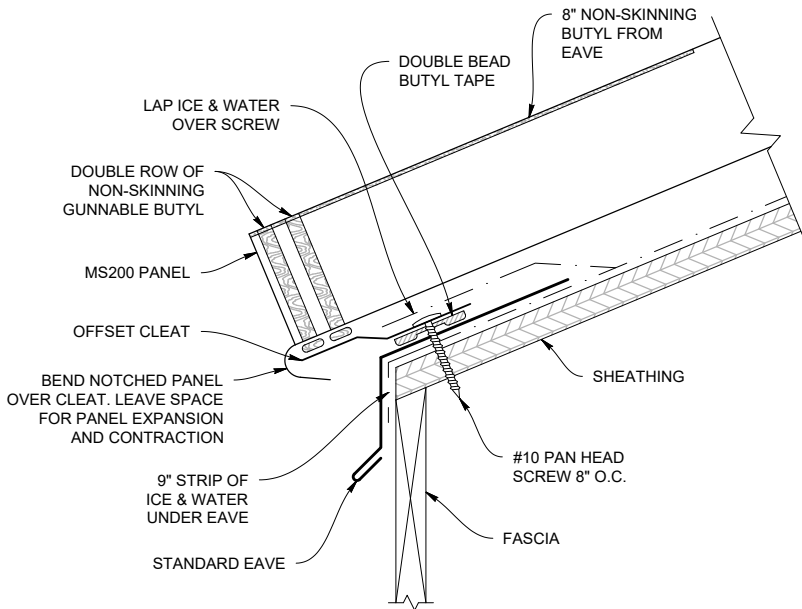

STANDARD EAVE (MS200ES)

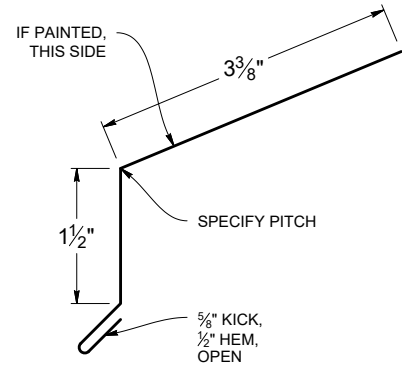

OFFSET CLEAT (MS200OC)

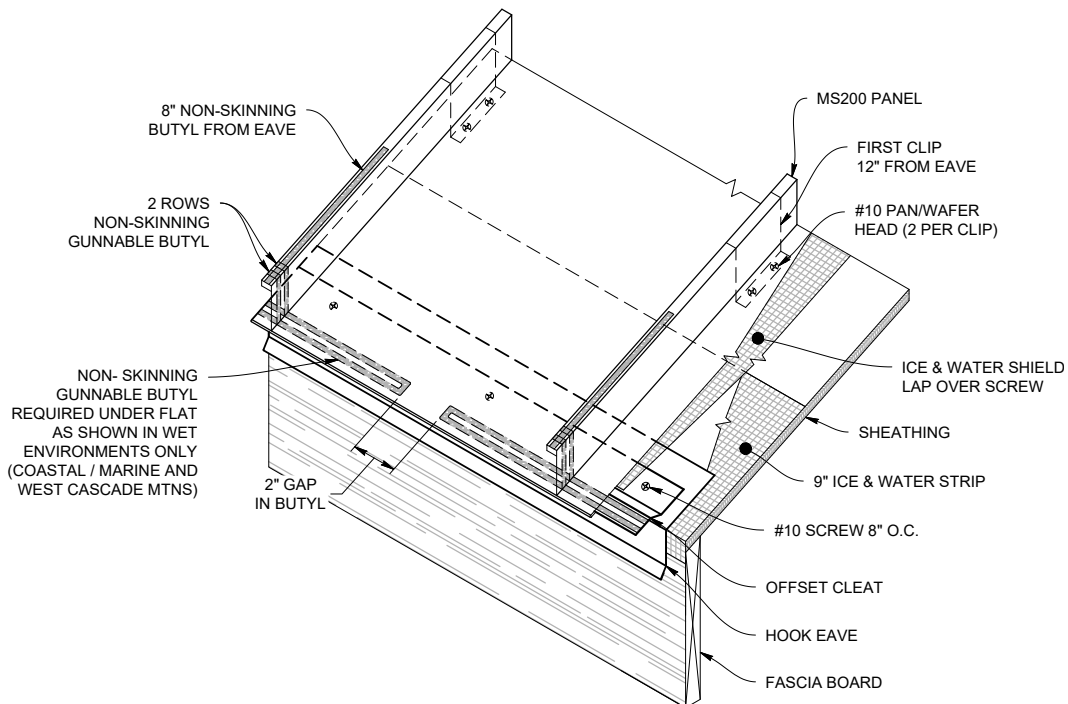
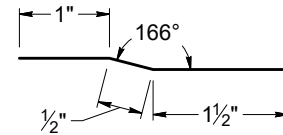

Note: All screws must be fastened into solid substrate.
Flashing must be lapped 4" with 3 rows of gunnable sealant.

HOOK EAVE DETAIL

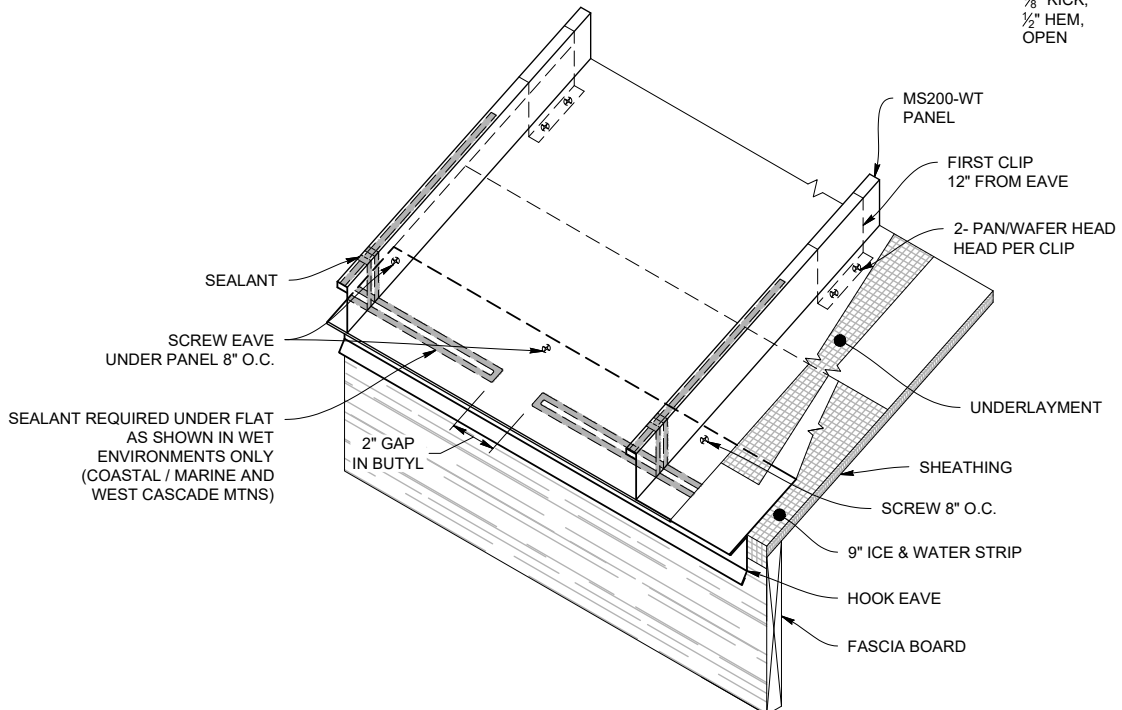
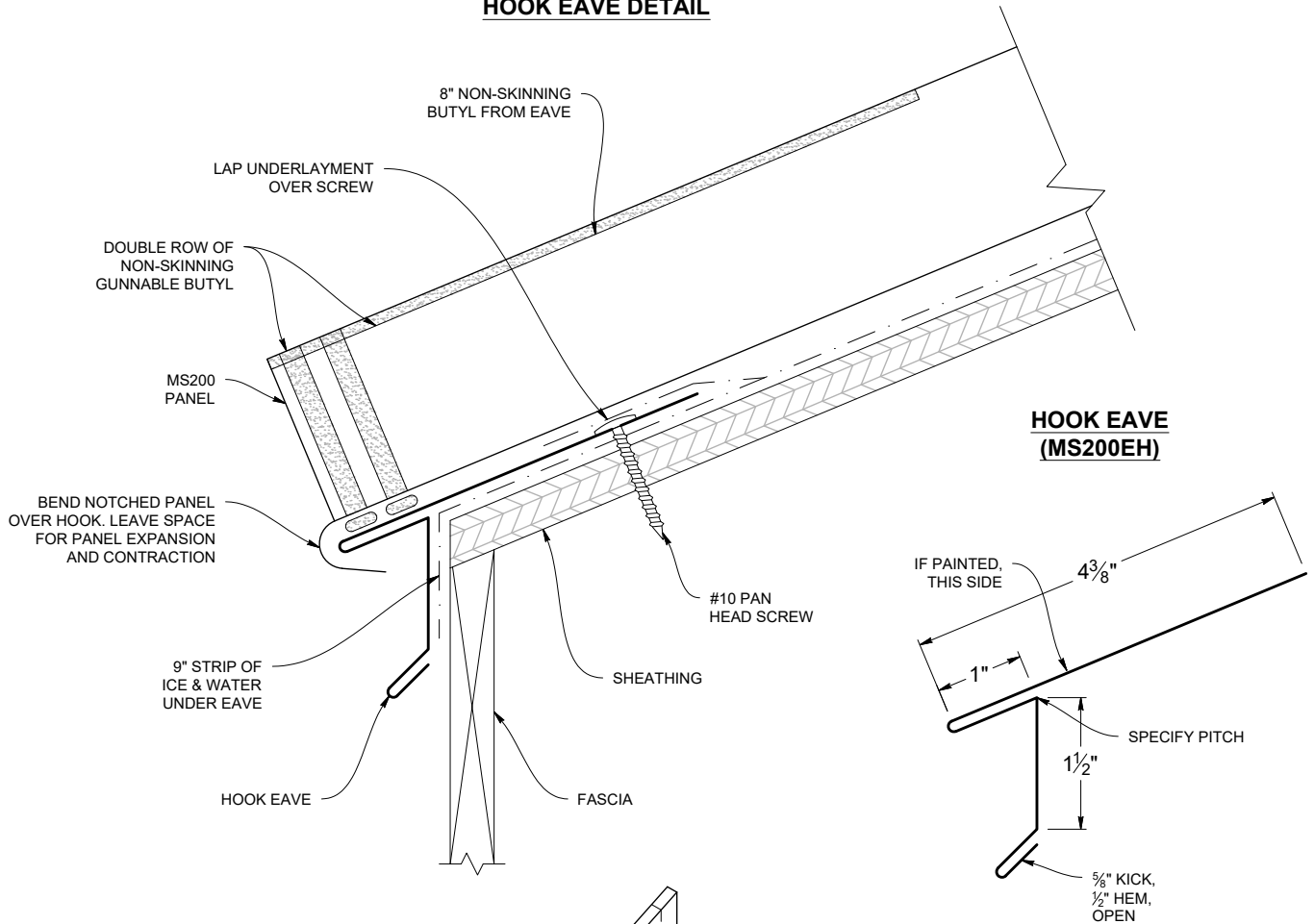

Note: All screws must be fastened into solid substrate.
Flashing must be lapped 4" with 3 rows of gunnable sealant.

Gutter / Hook Eave

HOOK EAVE WITH GUTTER DETAIL

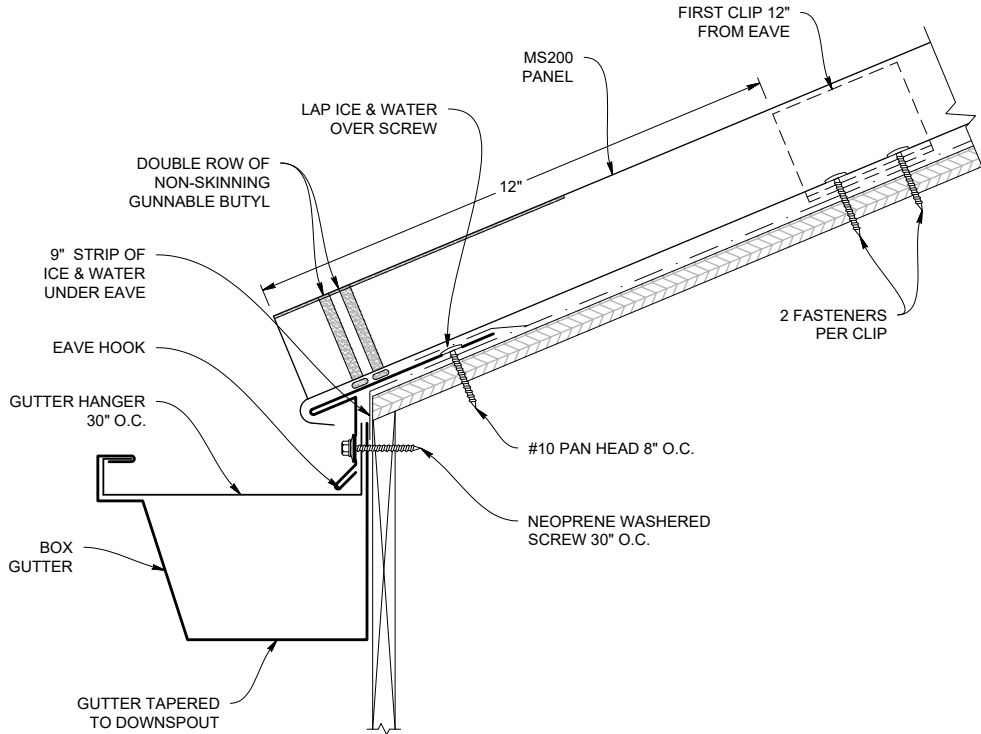

BOX GUTTER HANGER (AGH6)

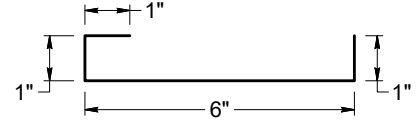

EAVE HOOK (MS200EH)

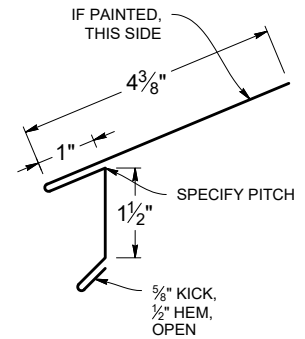

BOX GUTTER (MS200BG)

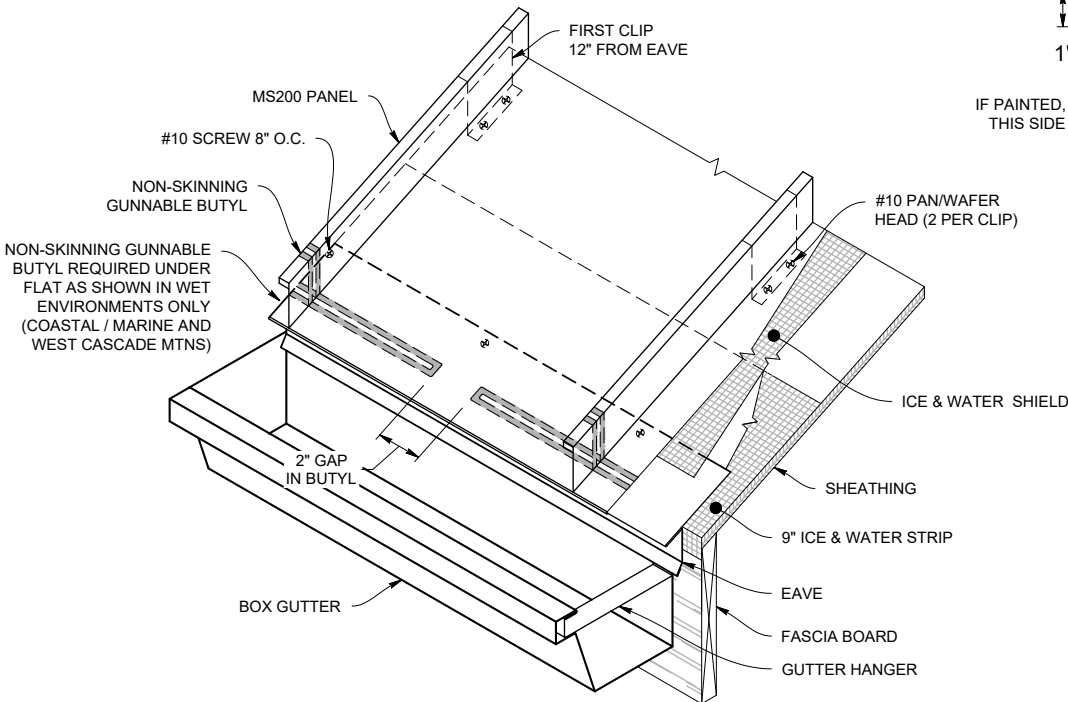
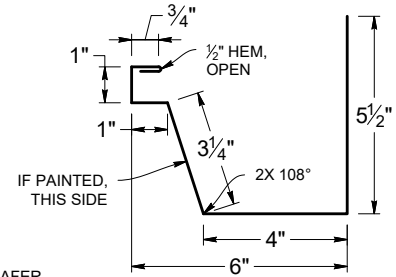

Note: All screws must be fastened into solid substrate.
Flashing must be lapped 4" with 3 rows of gunnable sealant.

STANDARD RIDGE DETAIL

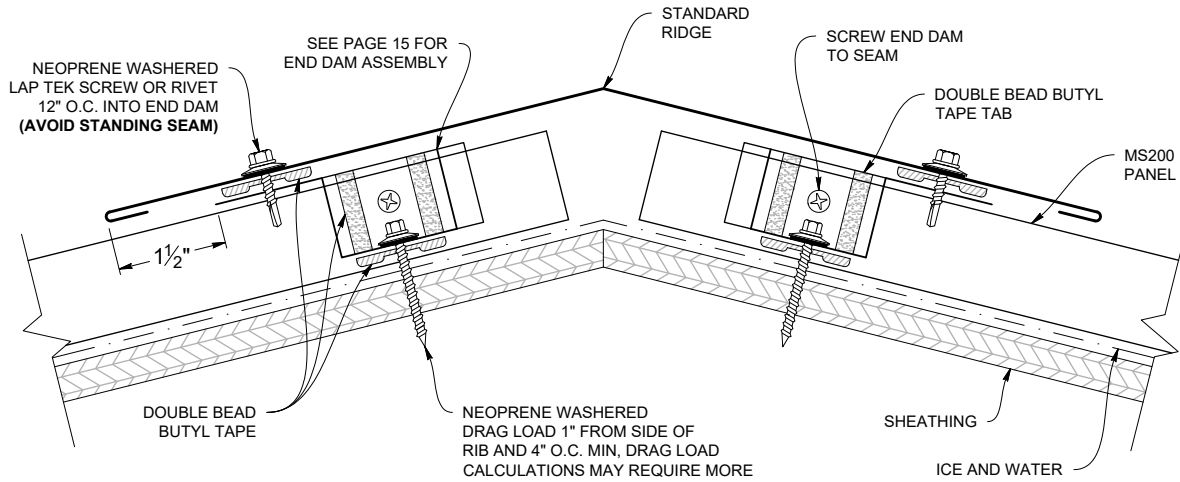

STANDARD RIDGE (MS200RS)

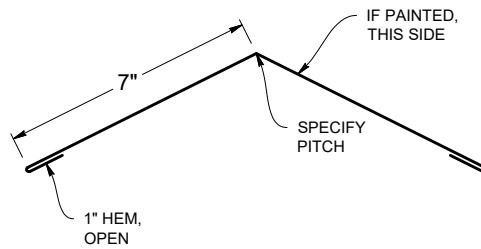

STANDARD RIDGE LAP

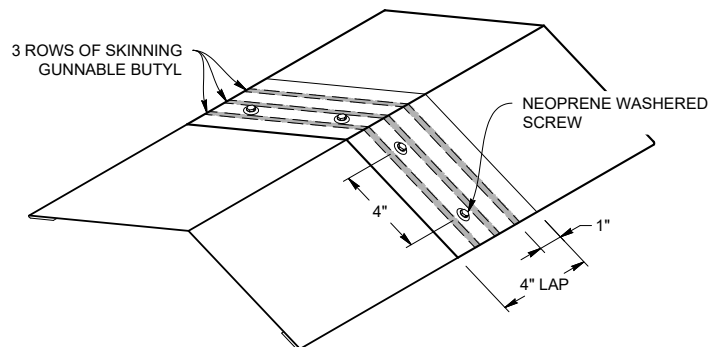

Note: All screws must be fastened into solid substrate.
Flashing must be lapped 4" with 3 rows of gunnable sealant.

Vented Ridge

WT VENTED RIDGE DETAIL

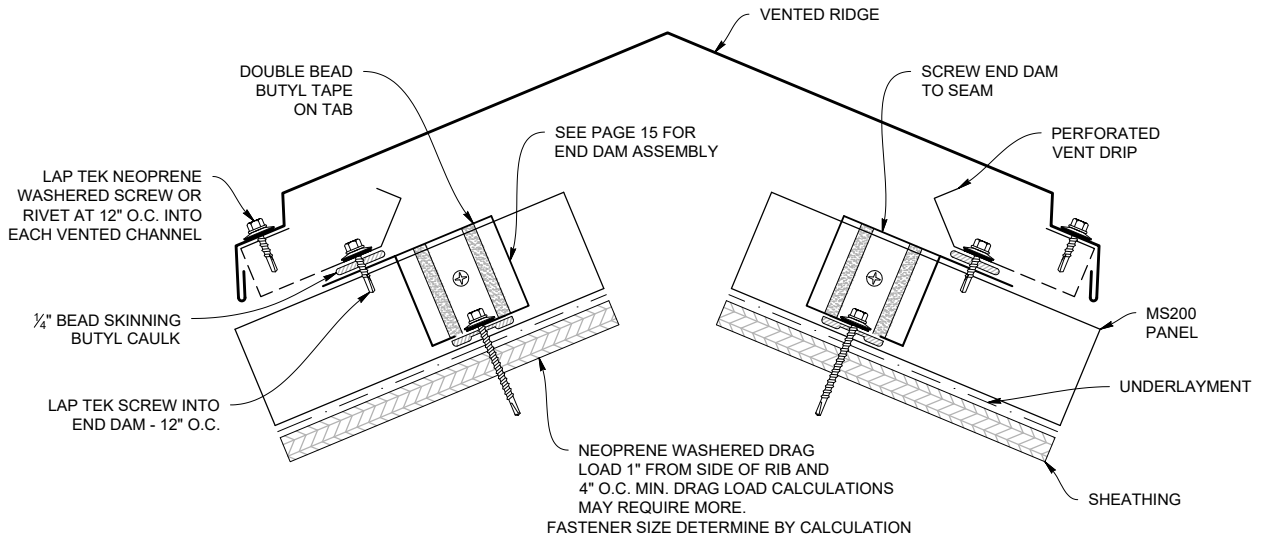

WT RIDGE FULL VENTED (MS200WTRFV)

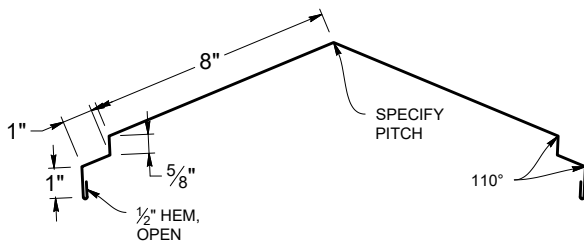

PERFORATED VENT DRIP (MS200PVD)

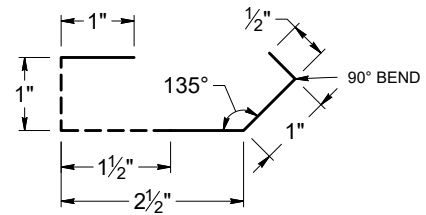

VENTED RIDGE LAP

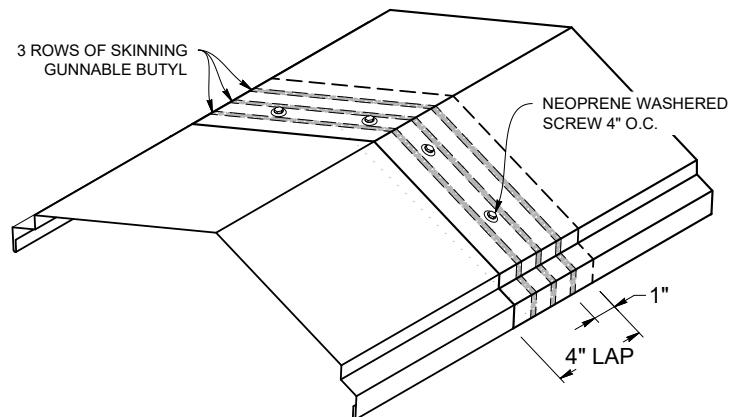

Note: All screws must be fastened into solid substrate.
Flashing must be lapped 4" with 3 rows of gunnable sealant.

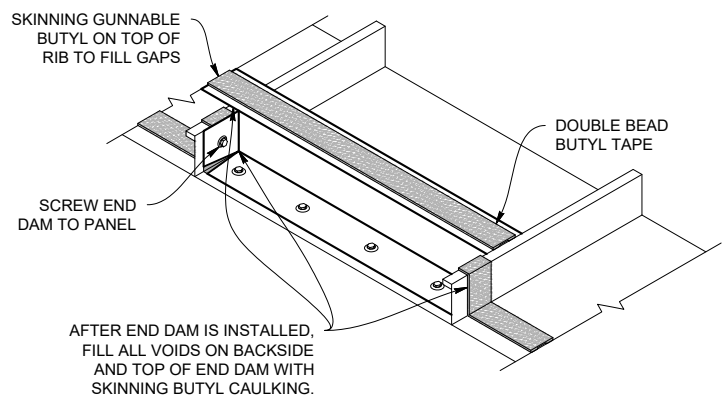
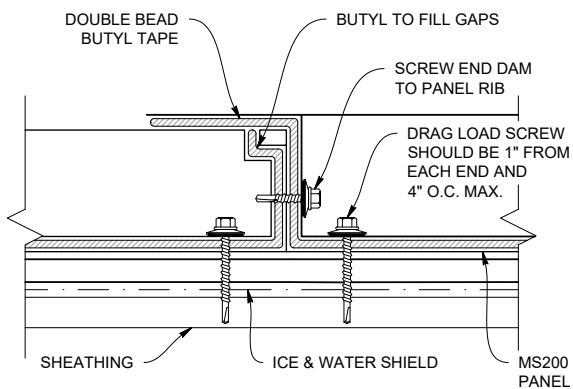
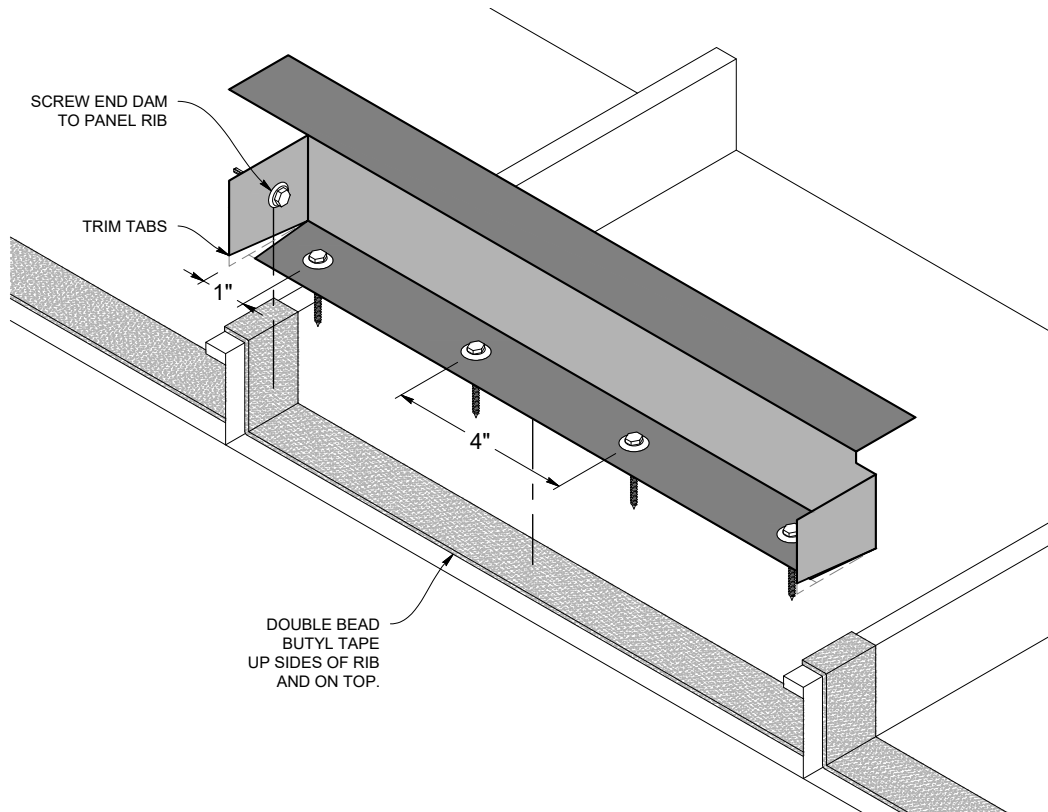

Note: All screws must be fastened into solid substrate.
Flashing must be lapped 4" with 3 rows of gunnable sealant.

Valley Flashing

Slope 3:12 or Greater



VALLEY (MS200VF)

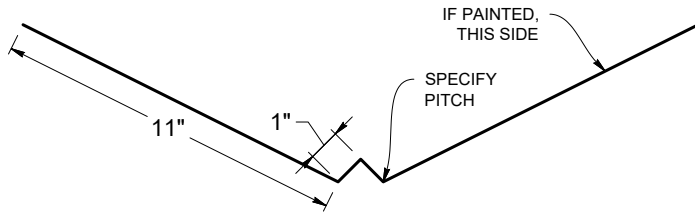

OFFSET CLEAT (MS200OC)

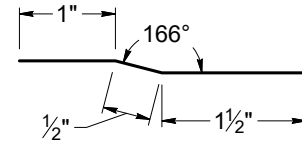

VALLEY DETAIL 3:12 or Greater Pitch

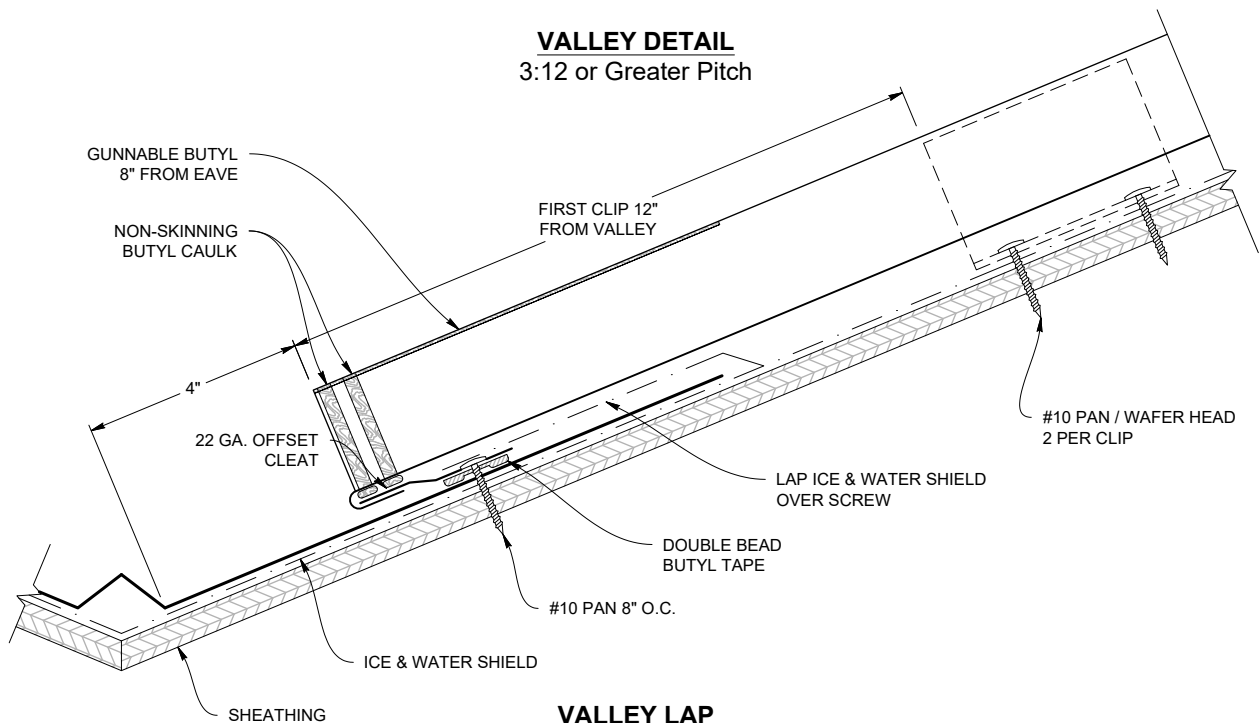

VALLEY LAP 3:12 or Greater Pitch

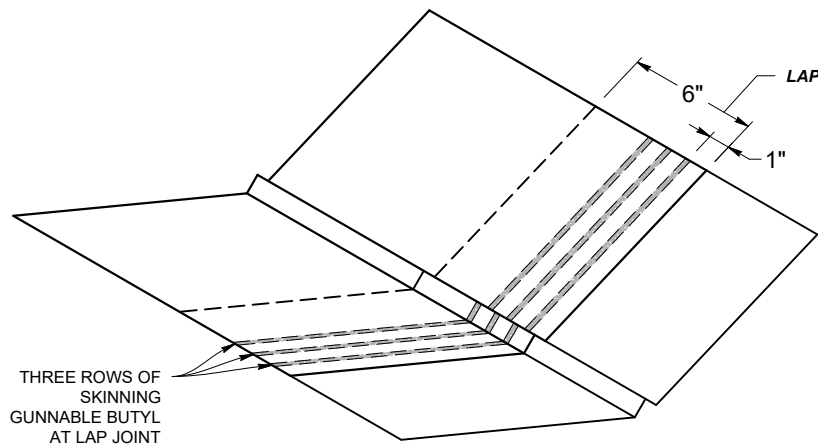

Note: All screws must be fastened into solid substrate.
Flashing must be lapped 4" with 3 rows of gunnable sealant.

Valley Flashing - Low Pitch

Slope Less than 3/12:12

VALLEY FLASHING (MS200VF)

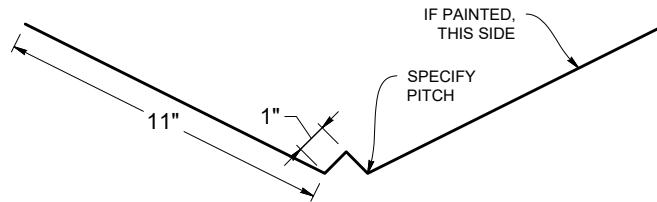

LOW SLOPE VALLEY DETAIL Less Than 3:12 Pitch

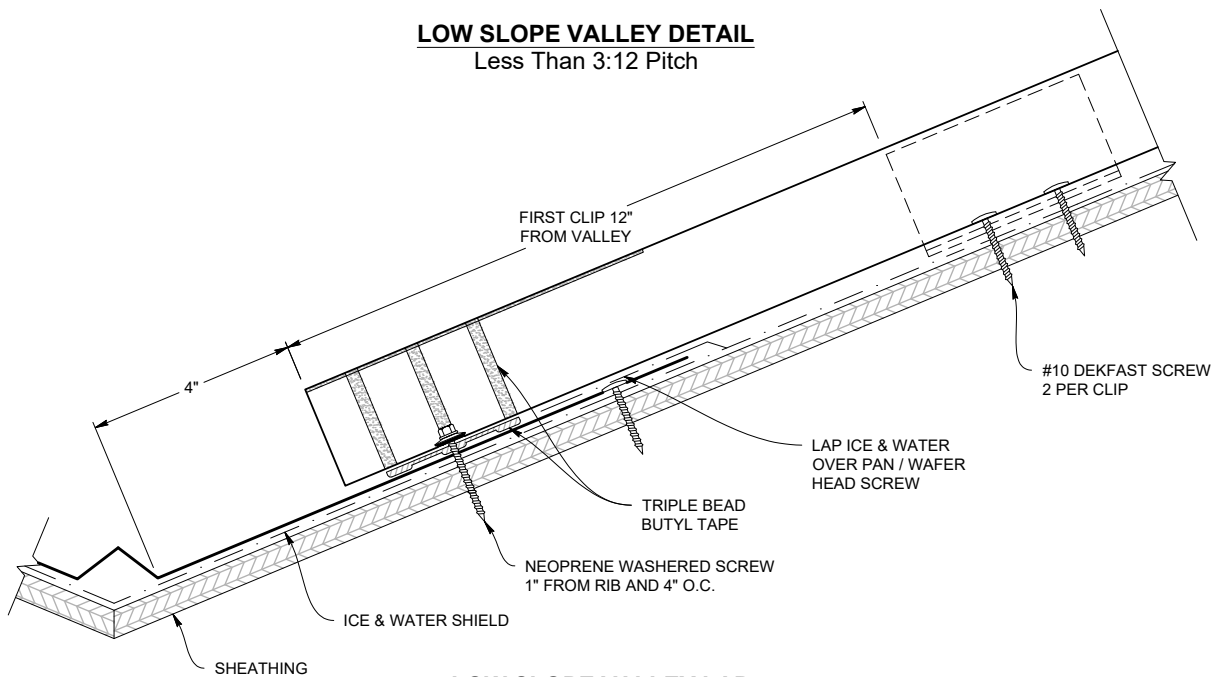

LOW SLOPE VALLEY LAP Less Than $\frac{3}{12}$ Pitch

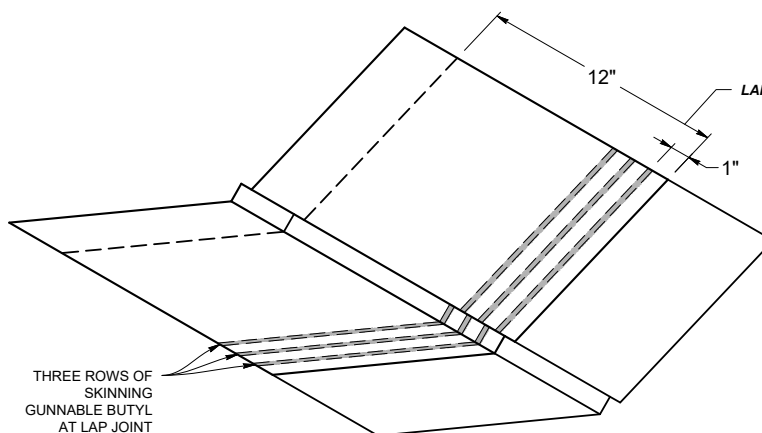

Note: All screws must be fastened into solid substrate.
Flashing must be lapped 4" with 3 rows of gunnable sealant.

Standard Gable



STANDARD GABLE DETAIL

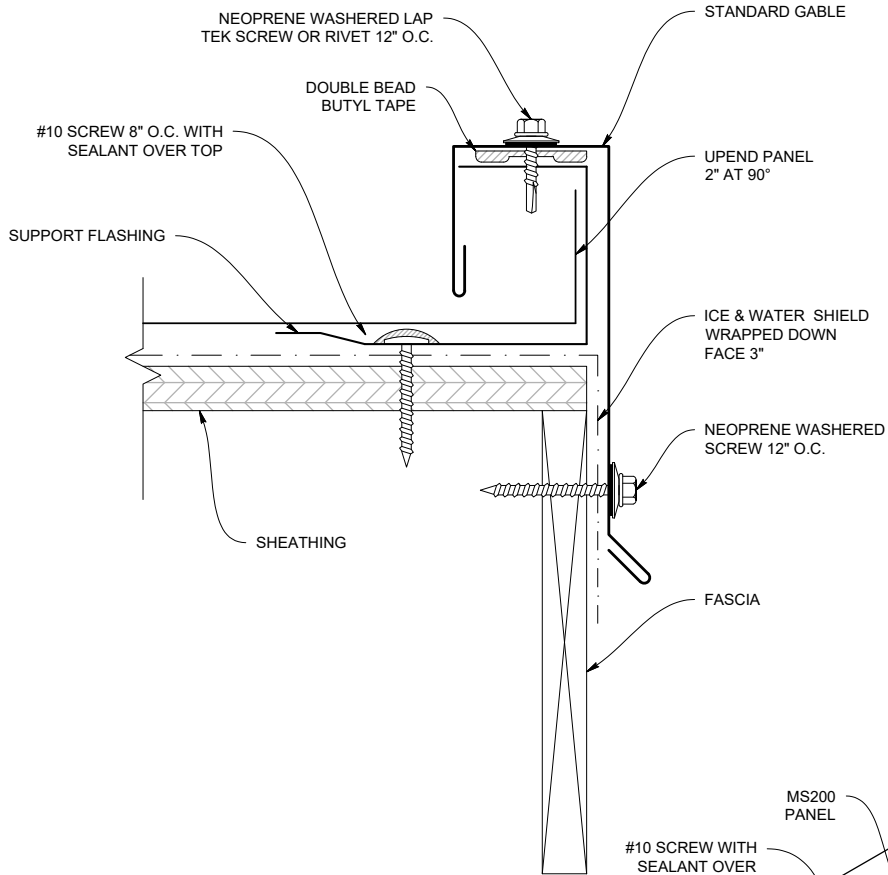

STANDARD GABLE (MS200GS)

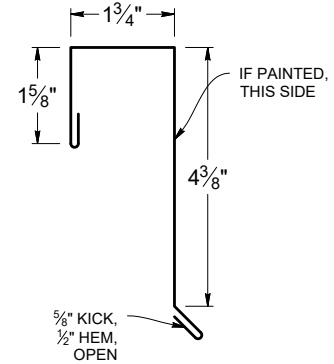

SUPPORT FLASHING (MS200SF)

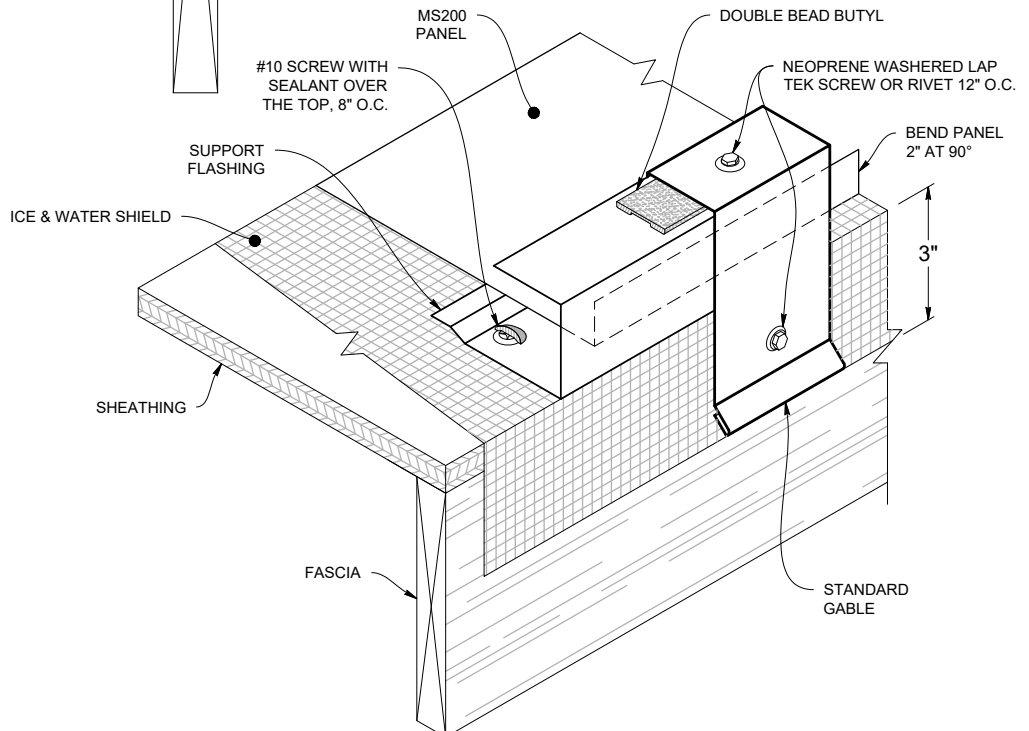
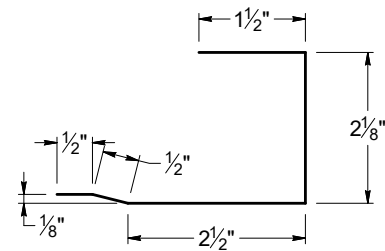

Note: All screws must be fastened into solid substrate.
Flashing must be lapped 4" with 3 rows of gunnable sealant.

ALTERNATE GABLE DETAIL

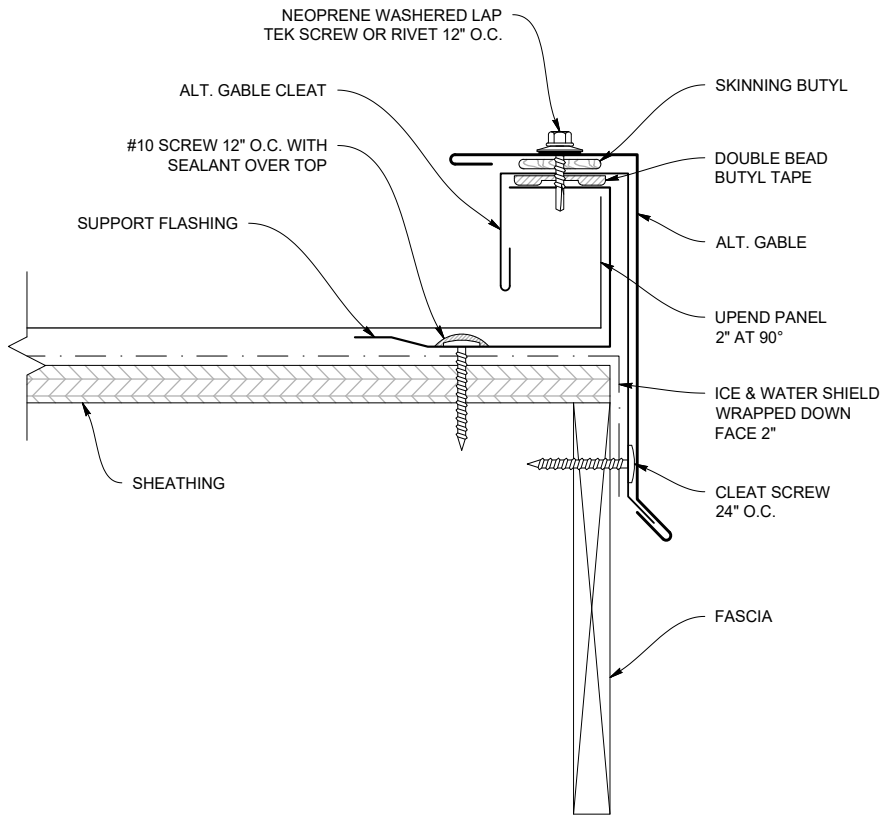

ALTERNATE GABLE (MS200AT)

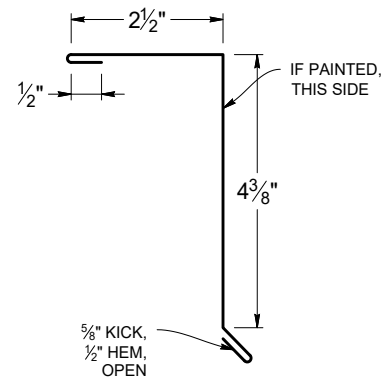

ALTERNATE GABLE CLEAT (MS200AGC)

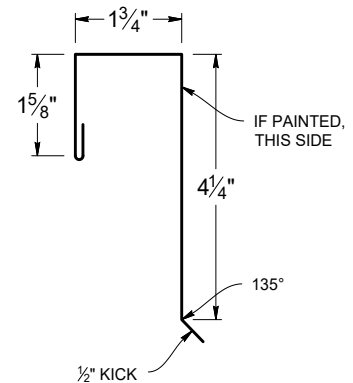

SUPPORT FLASHING (MS200SF)

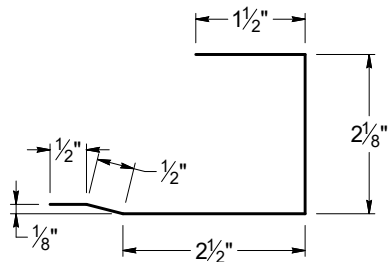

Note: All screws must be fastened into solid substrate.
Flashing must be lapped 4" with 3 rows of gunnable sealant.

SIDEWALL DETAIL

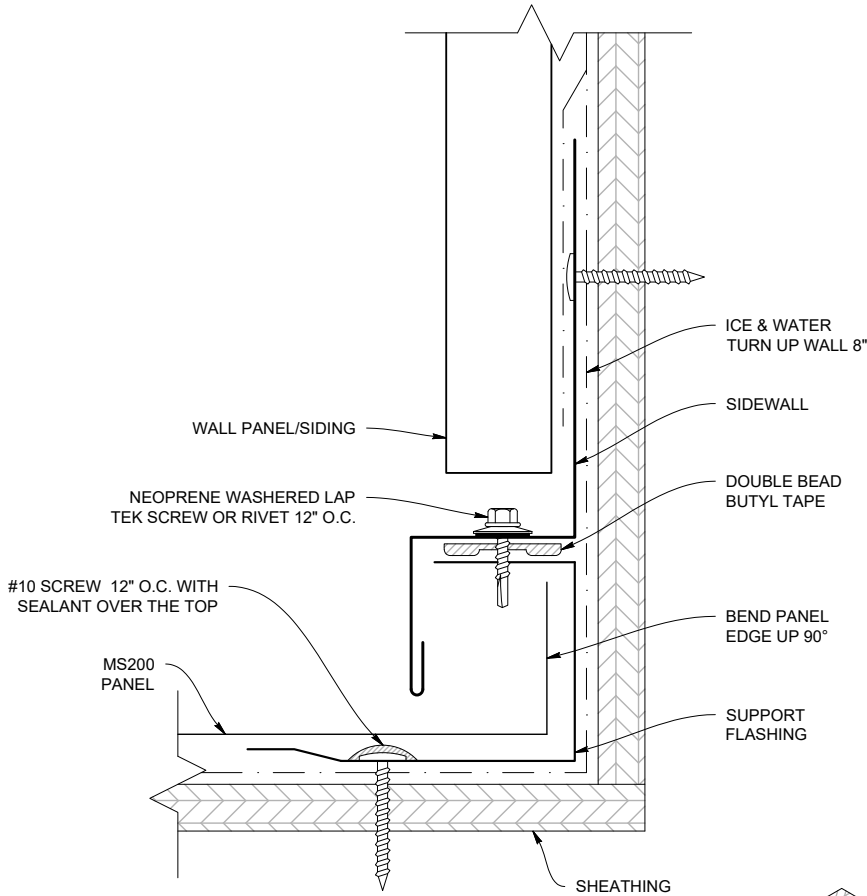

SIDEWALL (MS200SW)

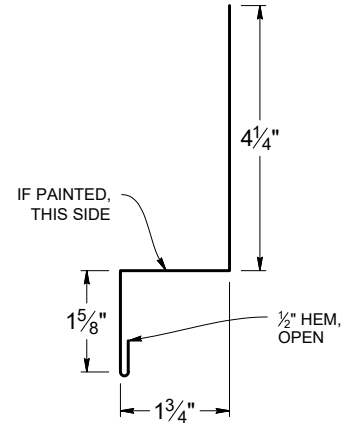

SUPPORT FLASHING (MS200SF)

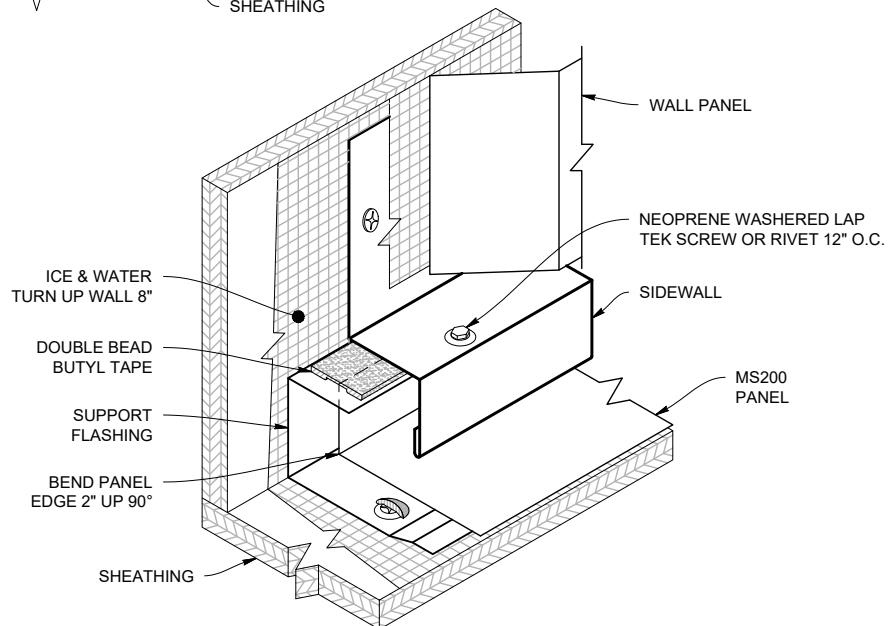
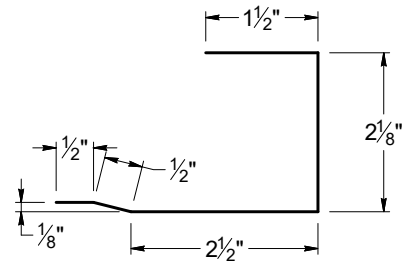

Note: All screws must be fastened into solid substrate.
Flashing must be lapped 4" with 3 rows of gunnable sealant.

PEAK FLASHING DETAIL (Ridge End Cap)

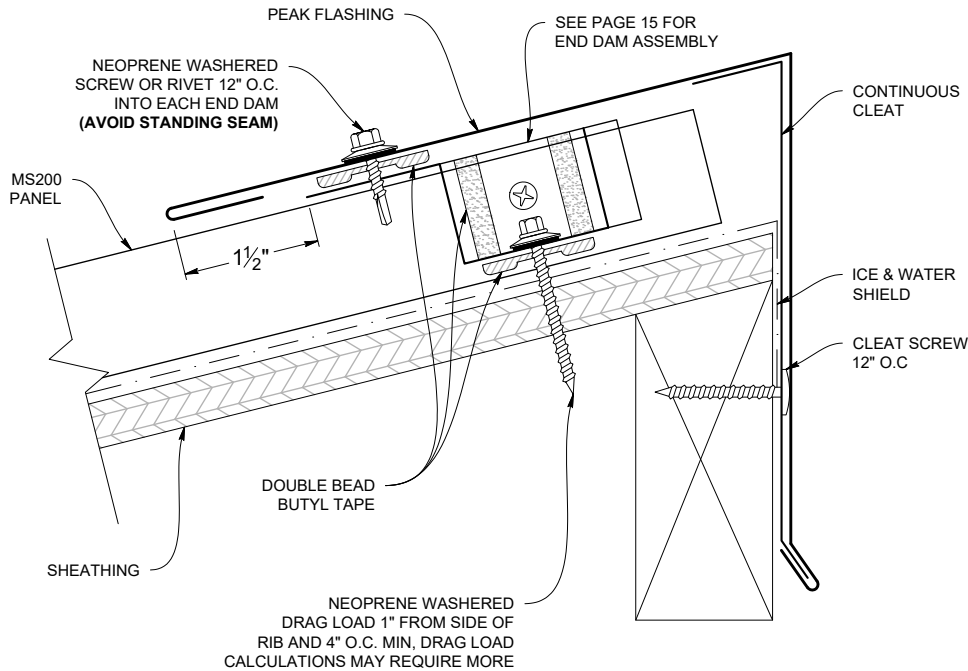

PEAK FLASHING (MS200REC)

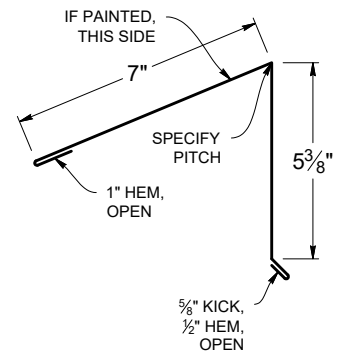

PEAK FLASHING LAP

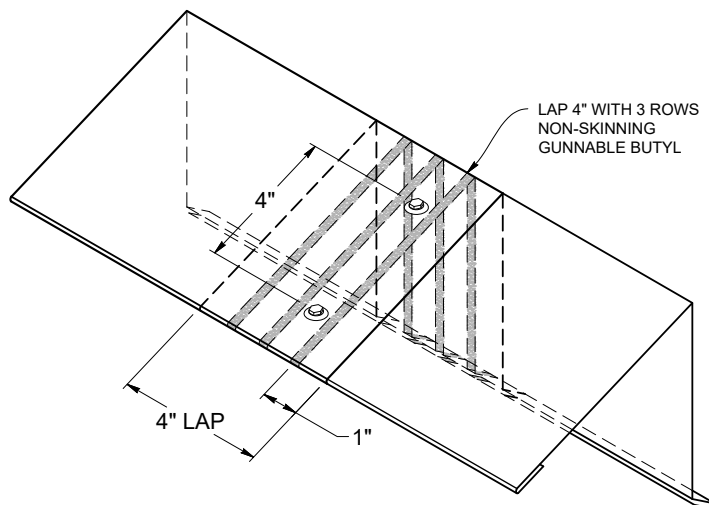

PEAK CLEAT (MS200RECC)

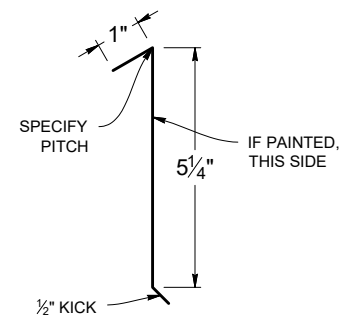

Note: All screws must be fastened into solid substrate.
Flashing must be lapped 4" with 3 rows of gunnable sealant.

Vented Peak Flashing

(Ridge End Cap)



WT VENTED PEAK FLASHING DETAIL (Vented Ridge End Cap)

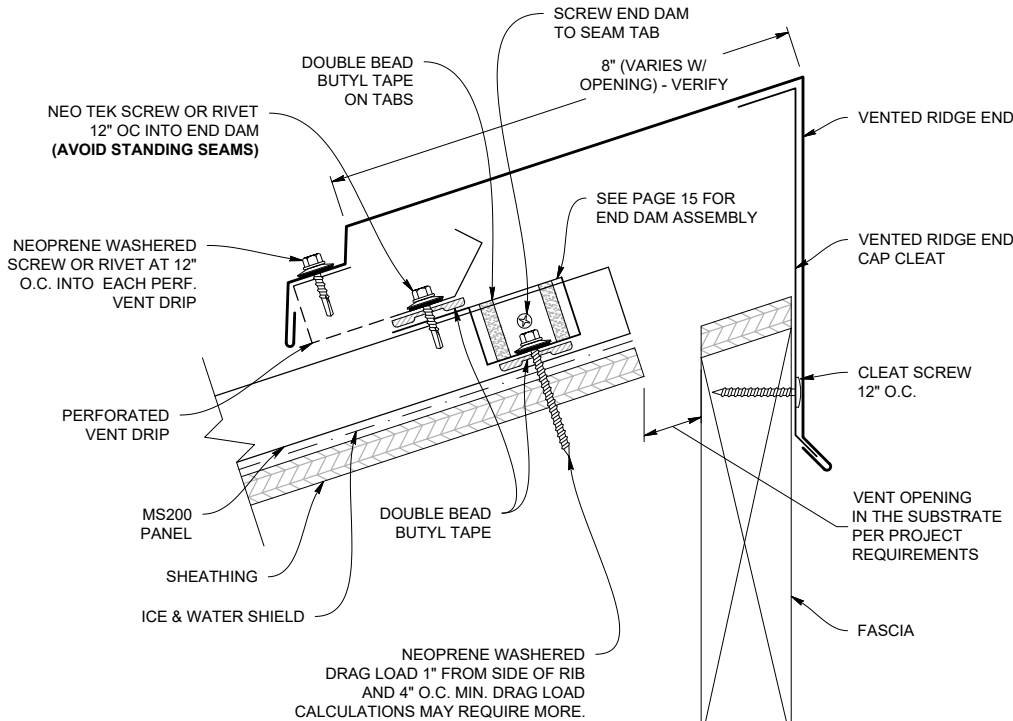

VENTED PEAK CLEAT (MS200VRECC)

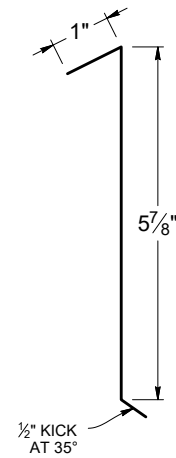

WT PEAK FLASHING (MS200WTRCV)

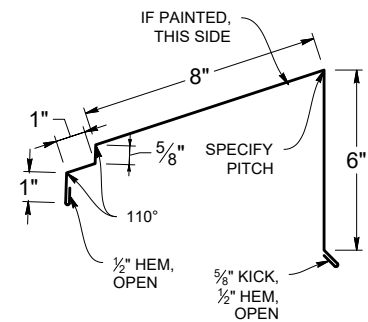

VENTED PEAK FLASHING LAP

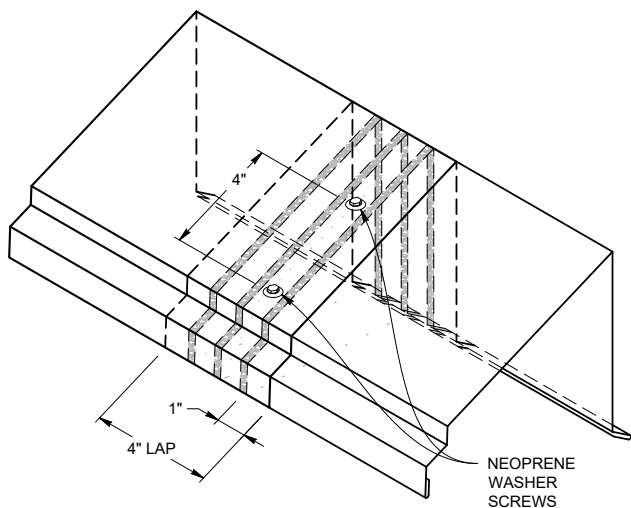

PERFORATED VENT DRIP (MS200PVD)

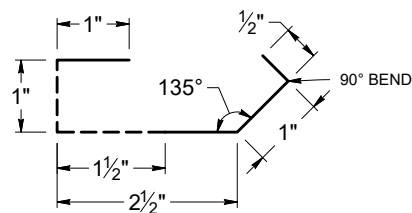

Note: All screws must be fastened into solid substrate.
Flashing must be lapped 4" with 3 rows of gunnable sealant.

PITCH CHANGE DETAIL

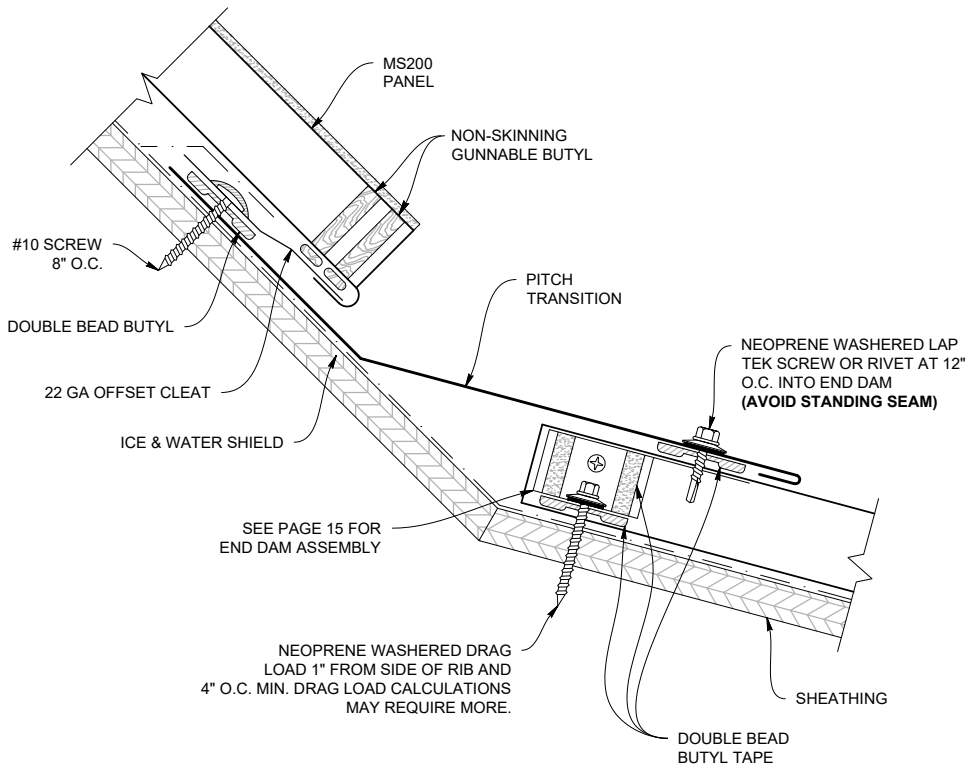

INSIDE PITCH CHANGE FLASHING

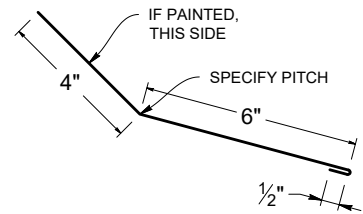

PITCH CHANGE LAP

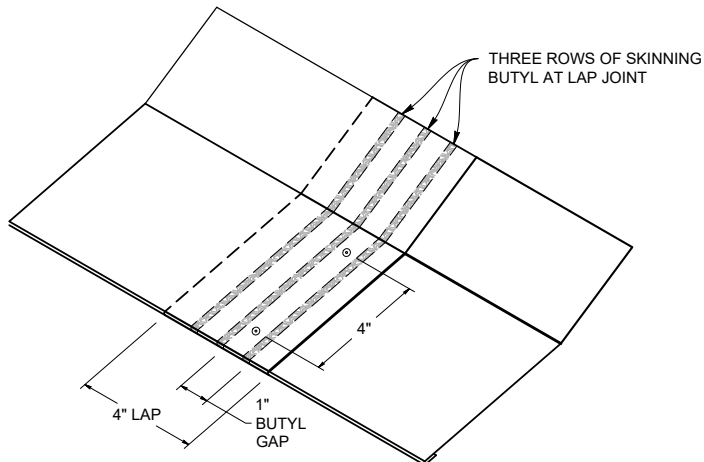

OFFSET CLEAT (MS200C)

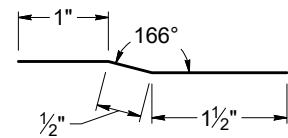

Note: All screws must be fastened into solid substrate.
Flashing must be lapped 4" with 3 rows of gunnable sealant.

ENDWALL DETAIL

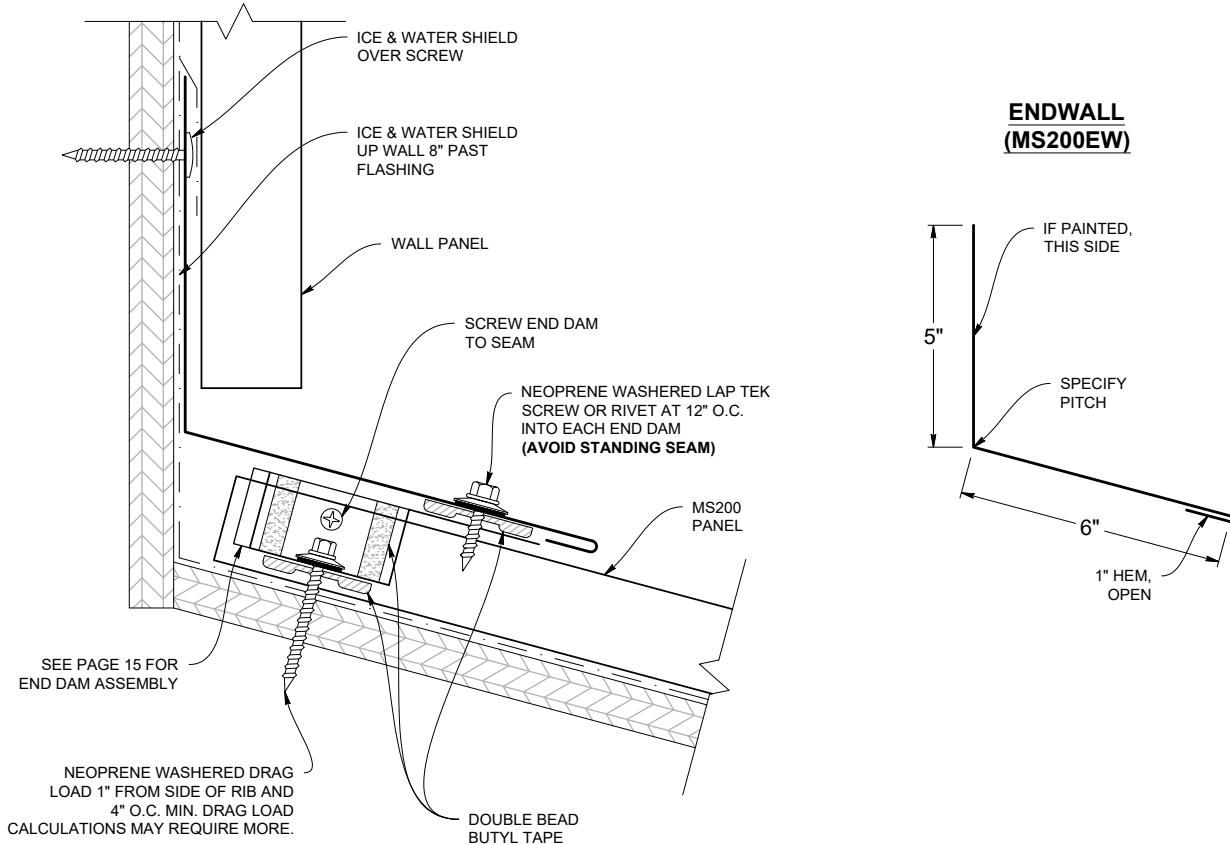

ENDWALL DETAIL

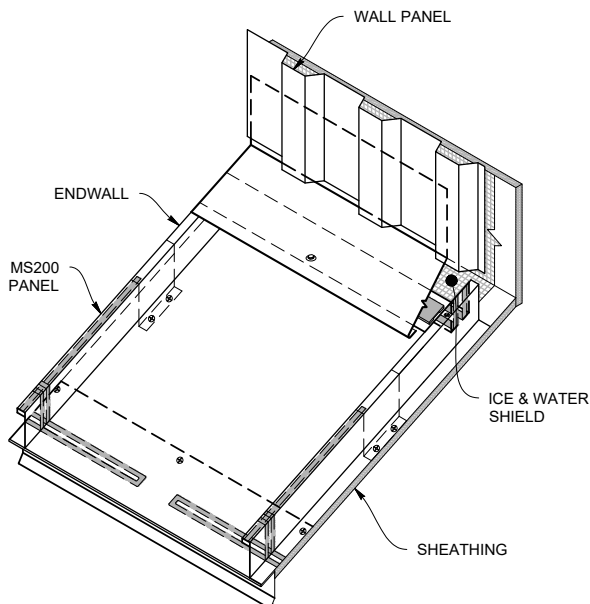

Note: All screws must be fastened into solid substrate.
Flashing must be lapped 4" with 3 rows of gunnable sealant.

WT VENTED ENDWALL DETAIL

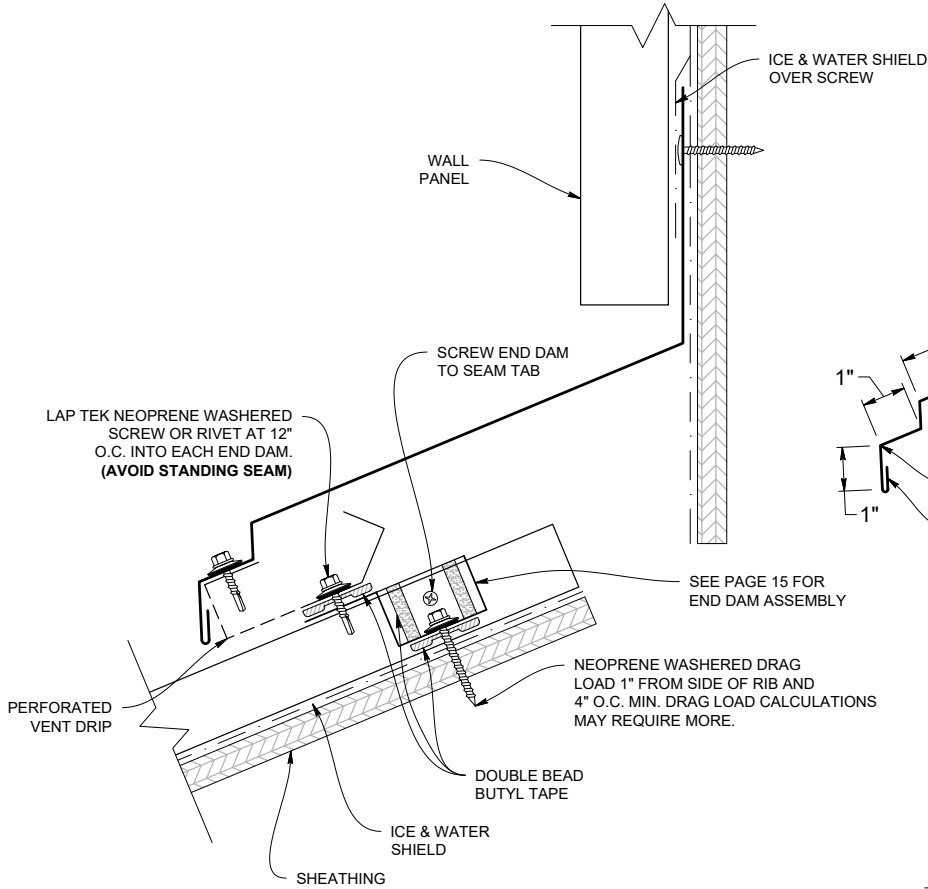

WT VENTED ENDWALL (MS200WTEWV)

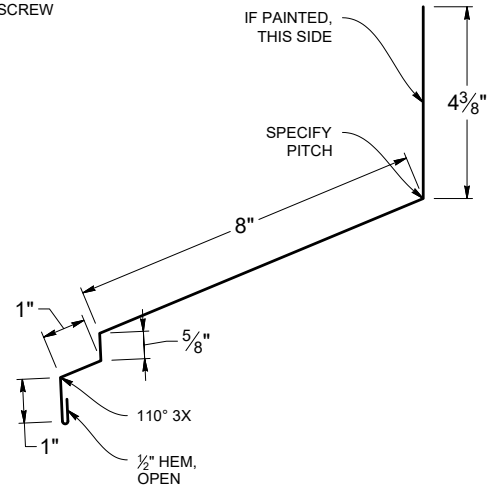

PERFORATED VENT DRIP (MS200PVD)

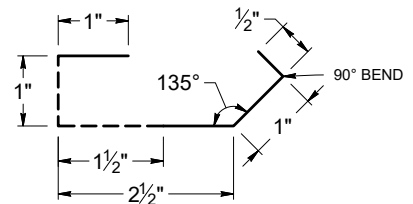

VENTED ENDWALL LAP

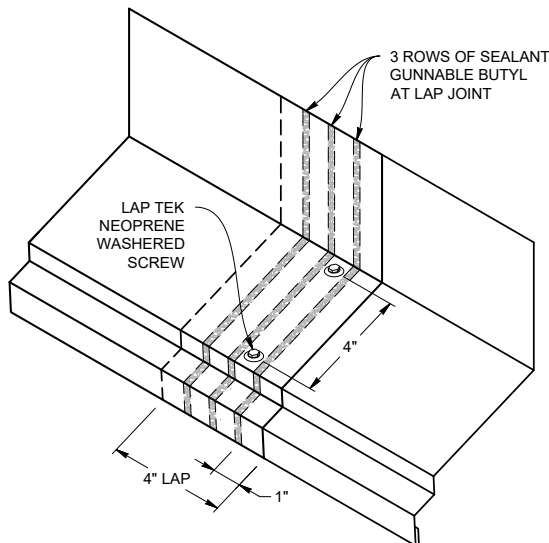

Note: All screws must be fastened into solid substrate.
Flashing must be lapped 4" with 3 rows of gunnable sealant.

Endwall w/ Saw Cut Reglet

SAW CUT ENDWALL DETAIL

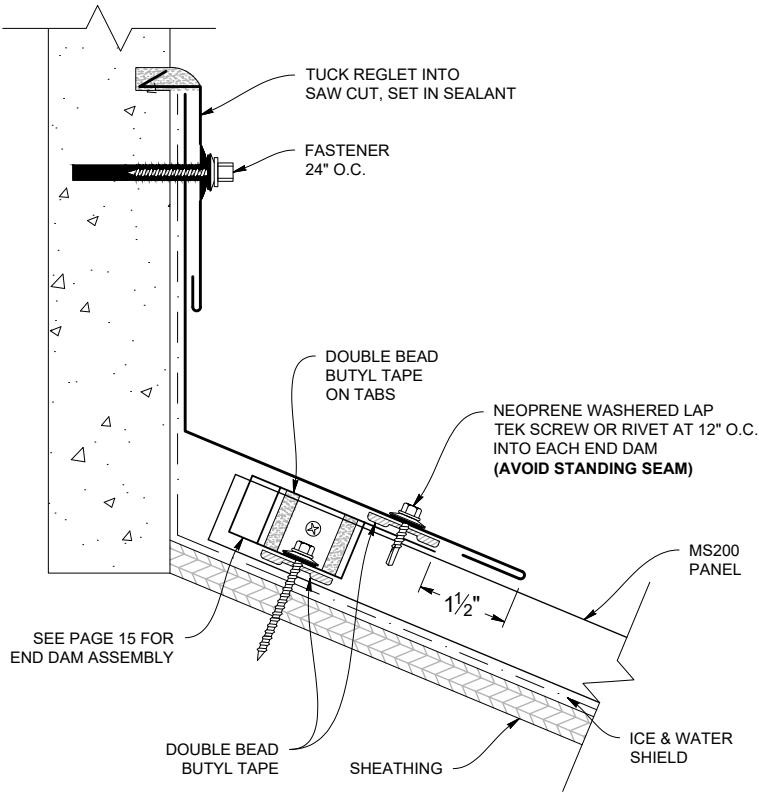

REGLET (MS200RF)

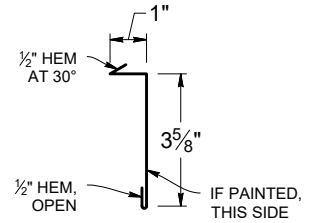

ENDWALL (MS200EW)

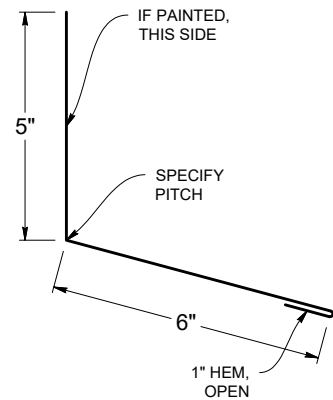

ENDWALL LAP

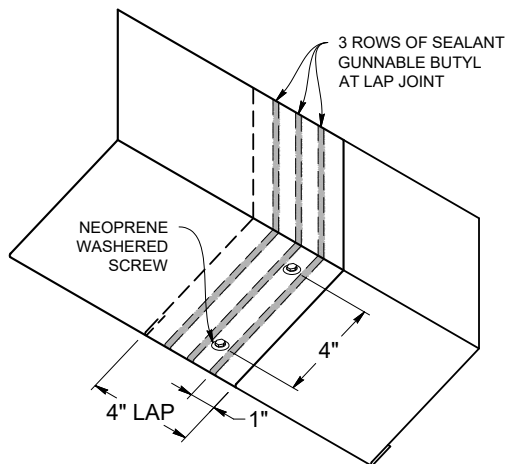

Note: All screws must be fastened into solid substrate.
Flashing must be lapped 4" with 3 rows of gunnable sealant.

STEP 1

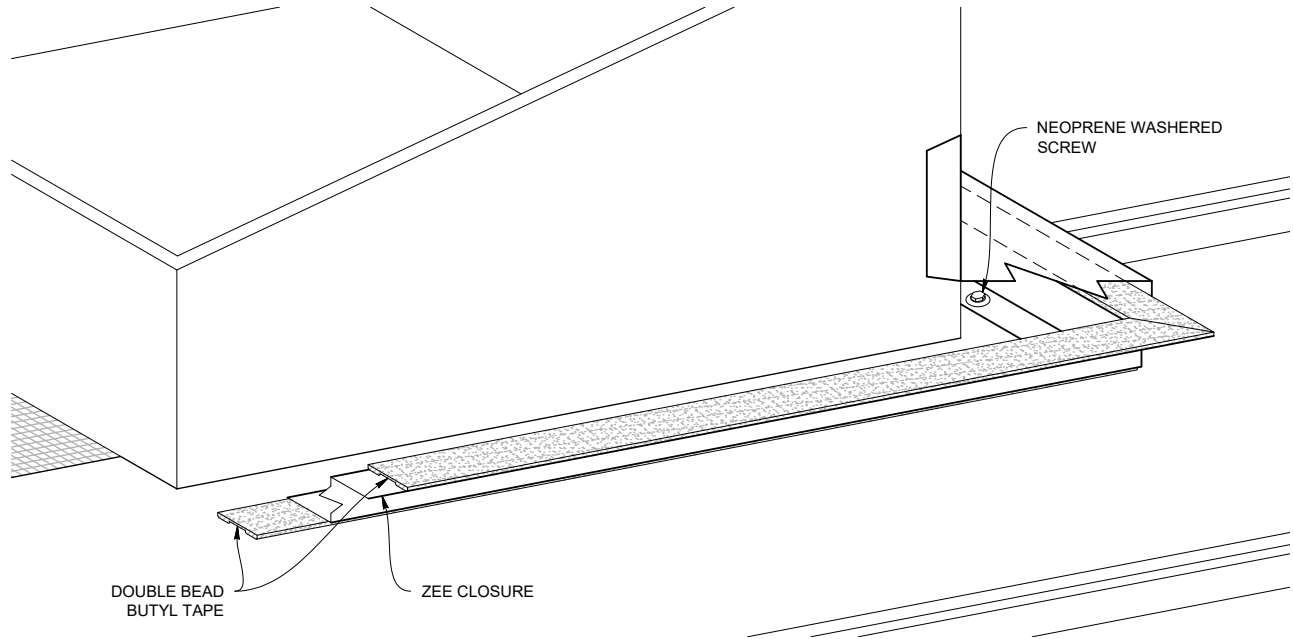

STEP 2

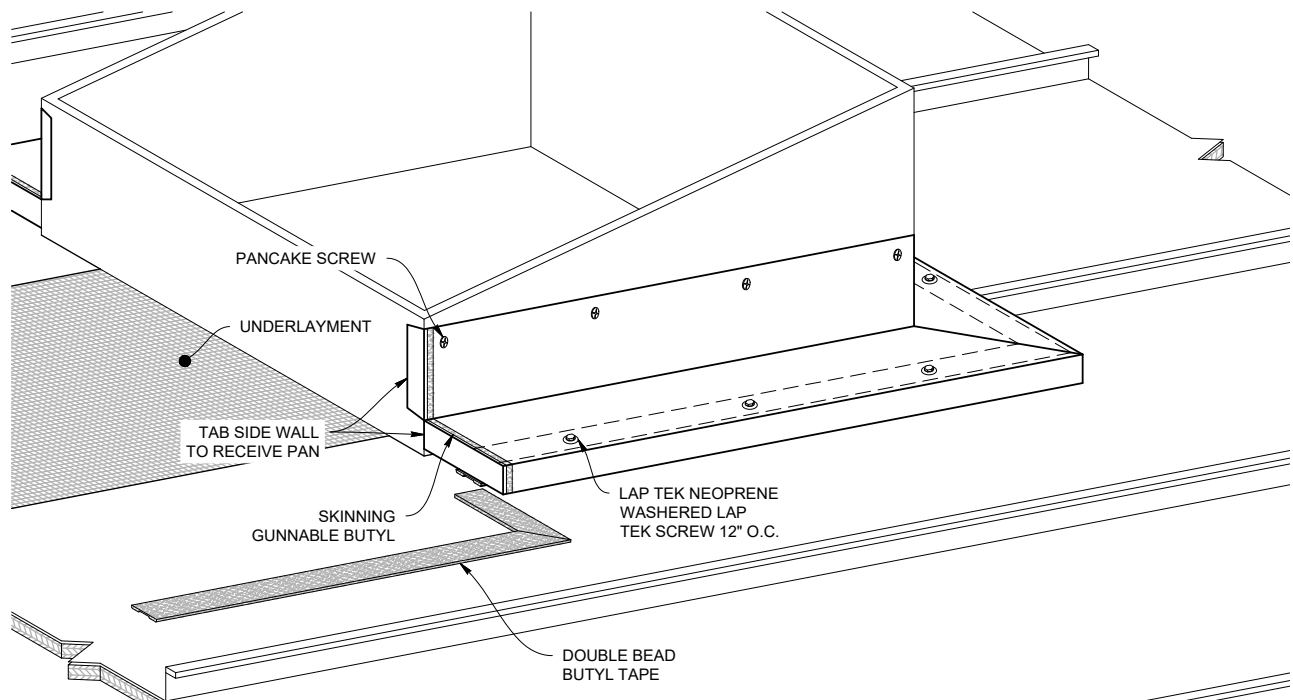

Note: All screws must be fastened into solid substrate.
Flashing must be lapped 4" with 3 rows of gunnable sealant.
Soldered or welded Stainless Steel crickets are allowed - except in corrosive environments. 27

Curb Back Pan/Cricket

STEP 3

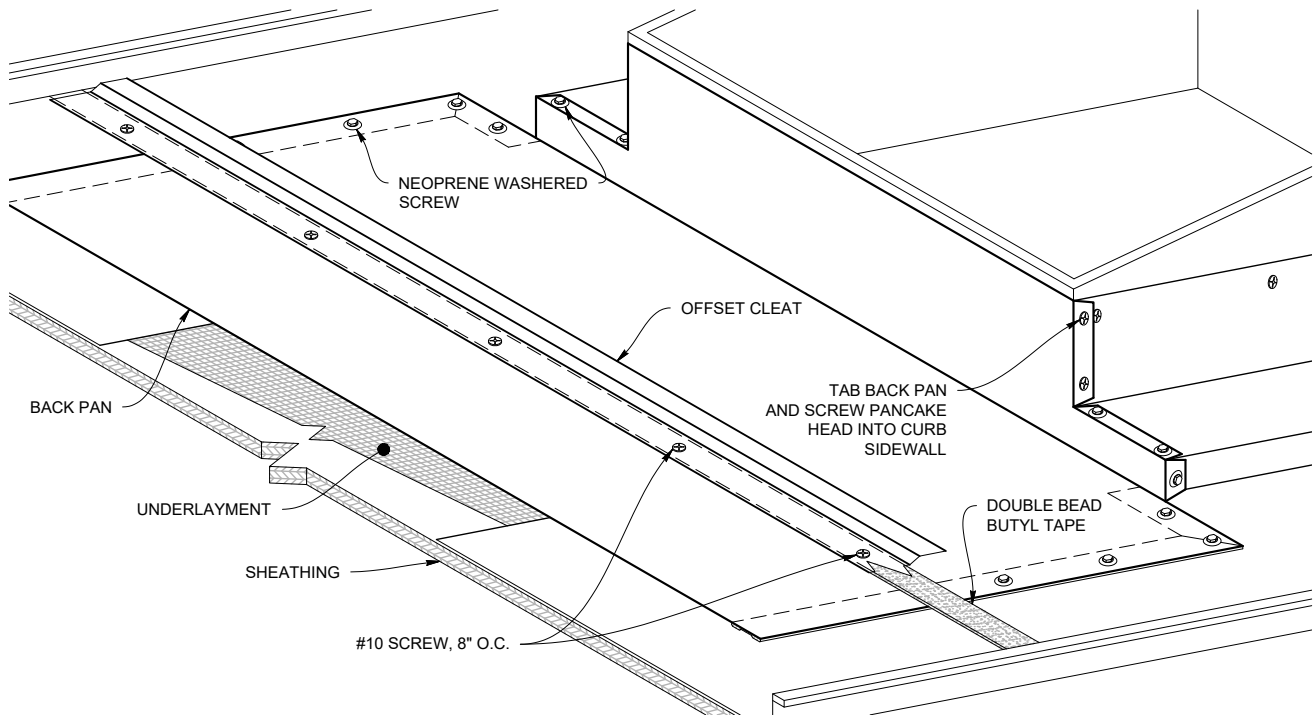

STEP 4

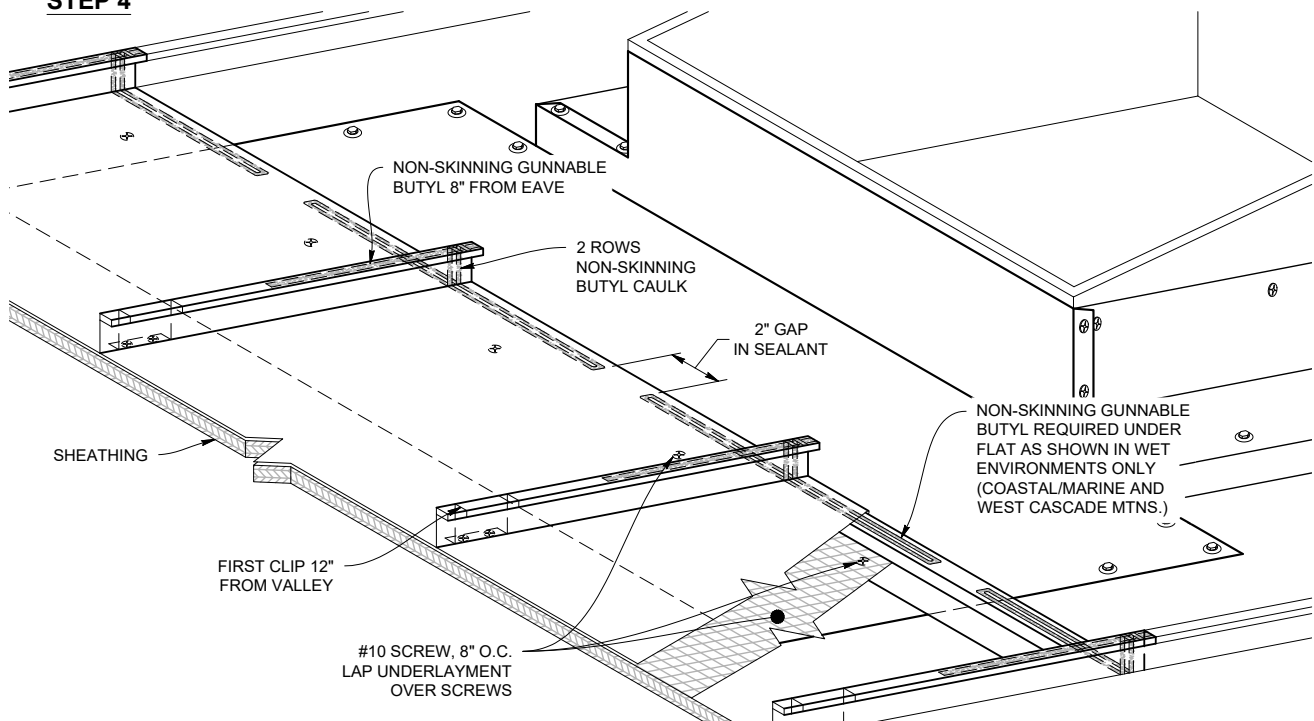

Note: All screws must be fastened into solid substrate.
Flashing must be lapped 4" with 3 rows of gunnable sealant.
Soldered or welded Stainless Steel crickets are allowed - except in corrosive environments.

STEP 5

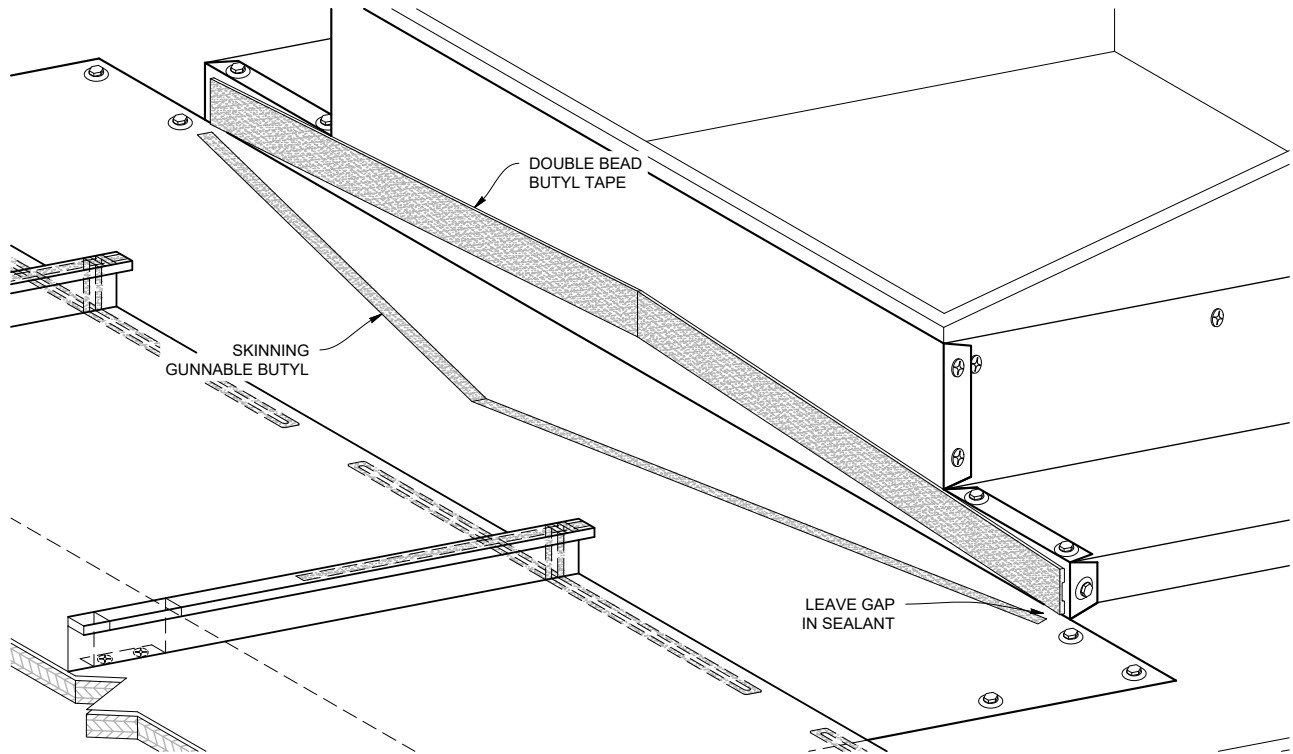

STEP 6

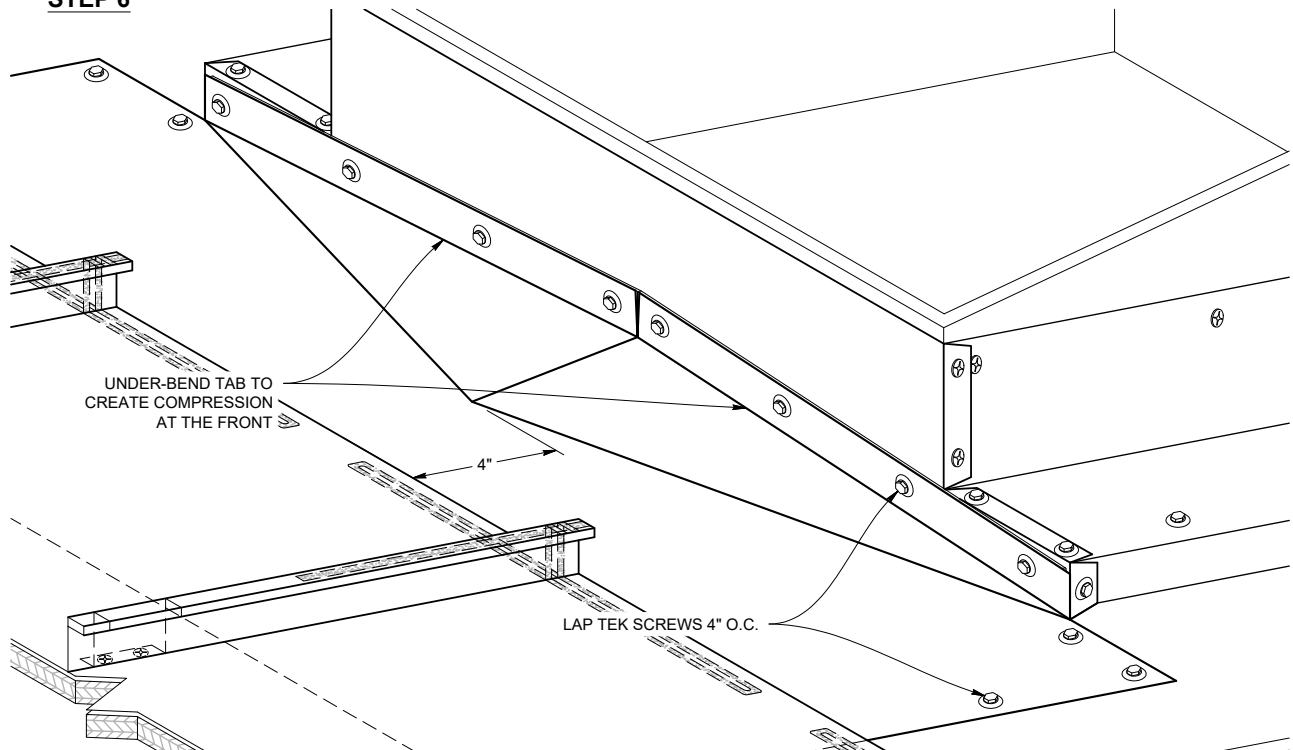

Note: All screws must be fastened into solid substrate.
Flashing must be lapped 4" with 3 rows of gunnable sealant.
Soldered or welded Stainless Steel crickets are allowed - except in corrosive environments. 29

CURB SIDEWALL DETAIL

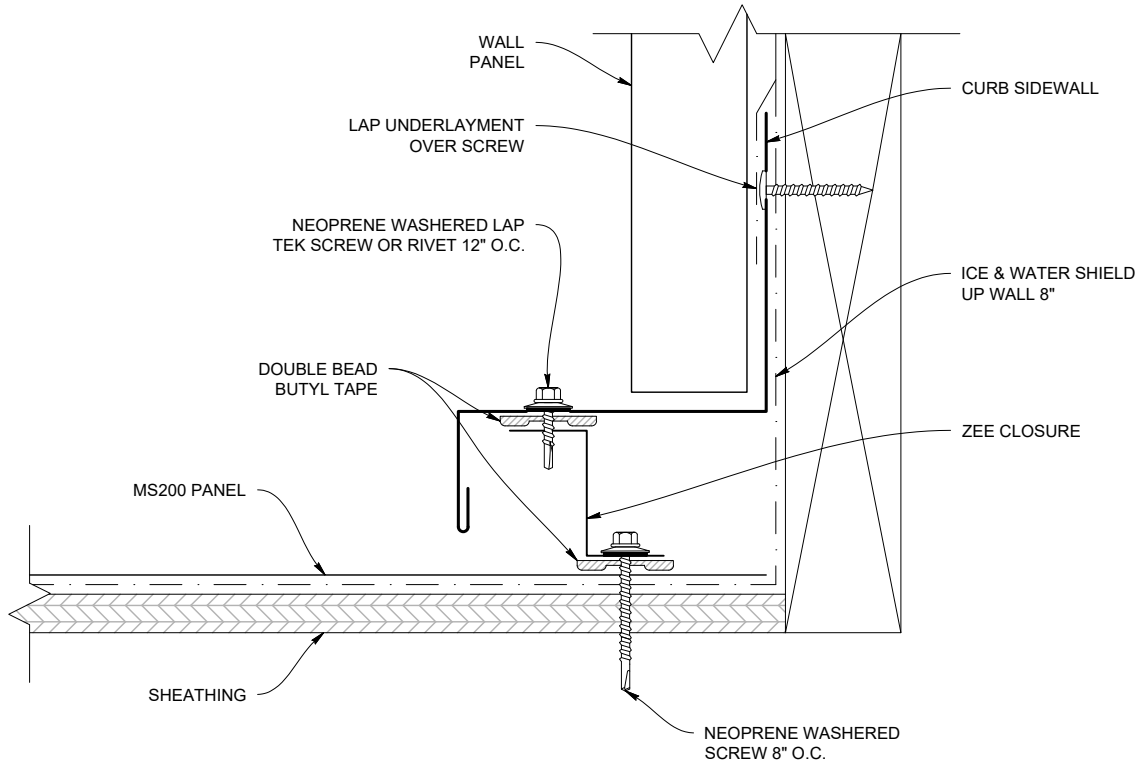

ZEE CLOSURE (MS200ZC)

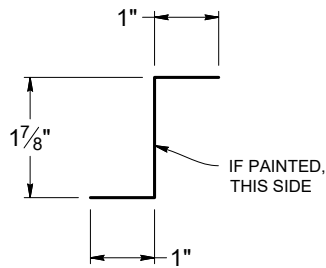

CURB SIDEWALL (MS200CSW)

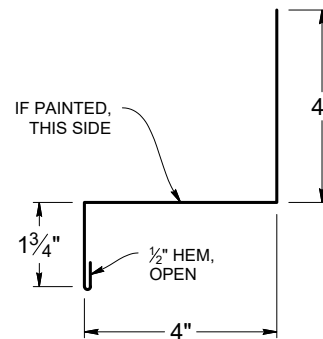

Note: All screws must be fastened into solid substrate.
Flashing must be lapped 4" with 3 rows of gunnable sealant.

CURB ENDWALL DETAIL

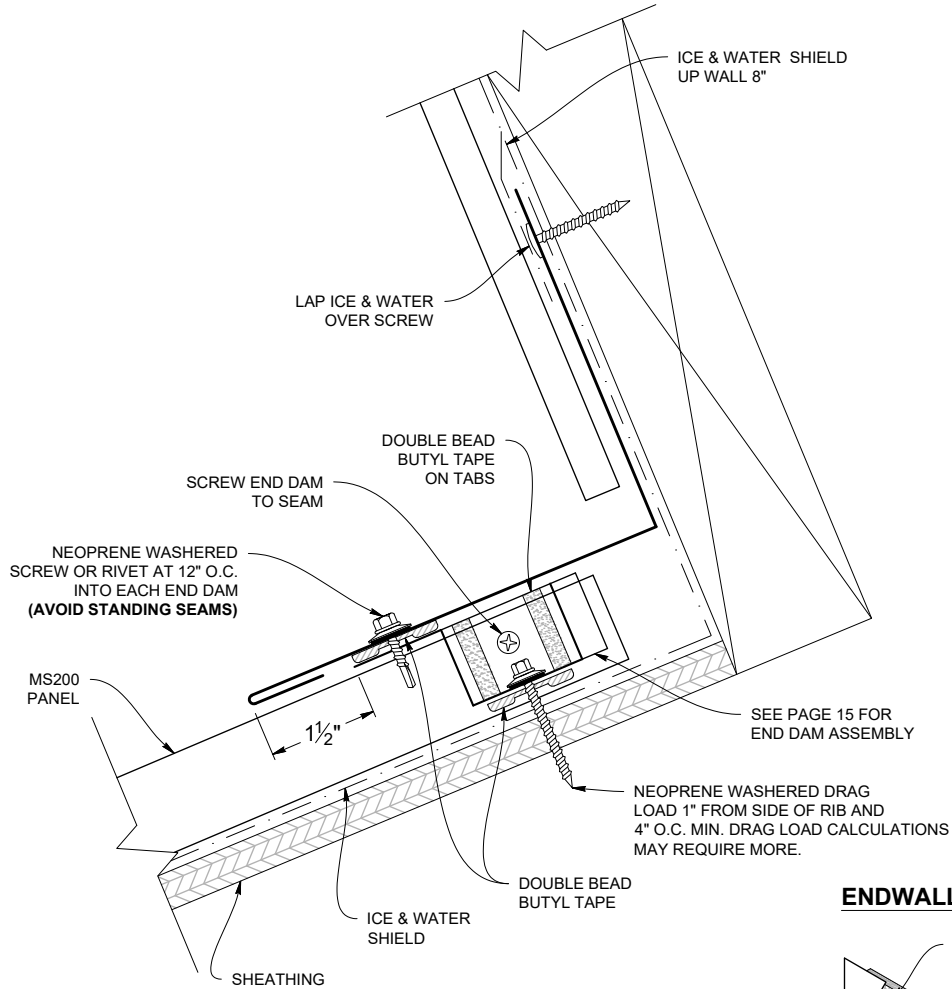

CURB ENDWALL (MS200CH)

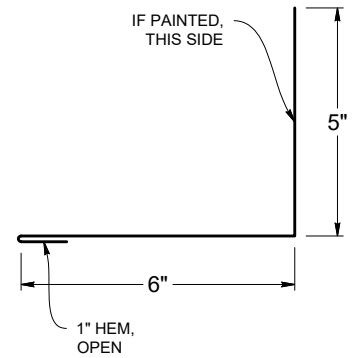

ENDWALL DETAIL

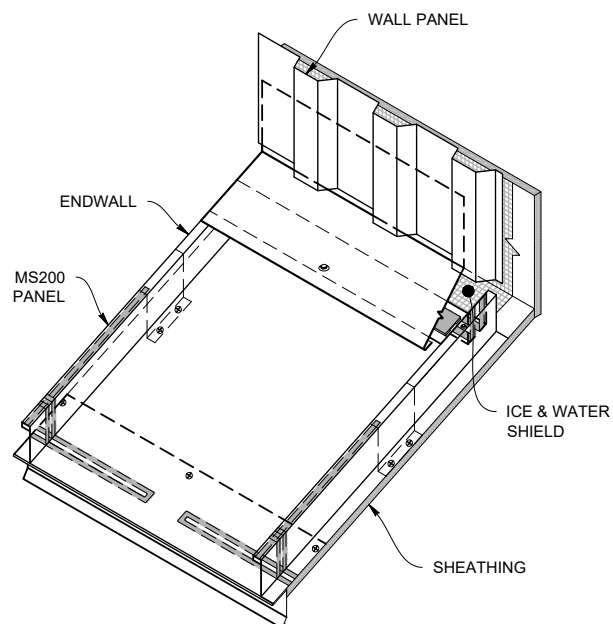

Note: All screws must be fastened into solid substrate.
Flashing must be lapped 4" with 3 rows of gunnable sealant.

Curb / Pan Cricket

(Slope 3:12 or Greater)

CURB BACK PAN / CRICKET DETAIL (3:12 Pitch or Greater)

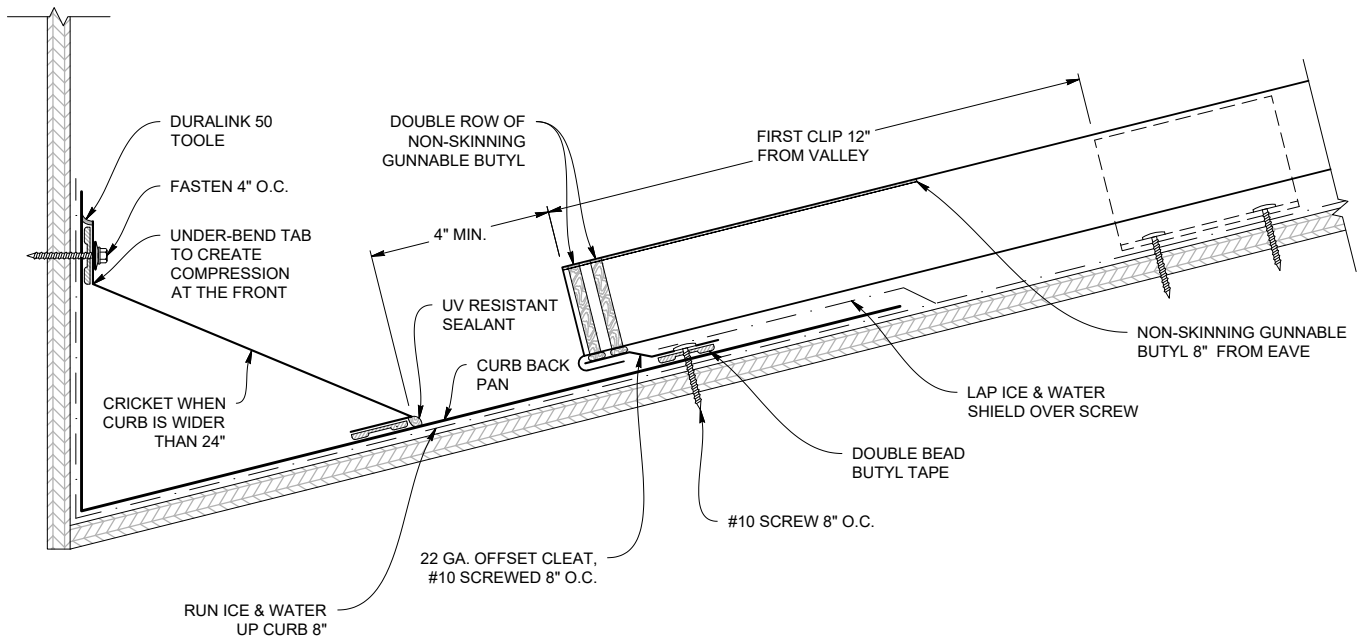

CURB BACK PAN / CRICKET DETAIL (Less Than 3:12 Pitch)

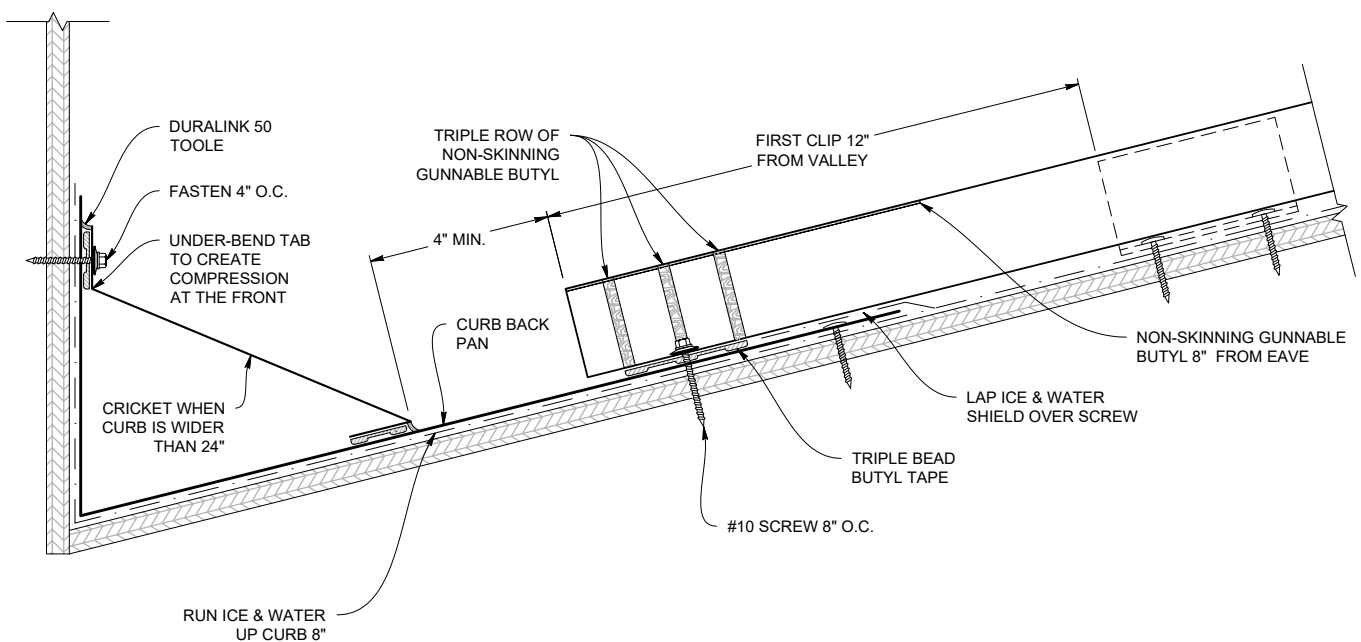

Note: All screws must be fastened into solid substrate.
Flashing must be lapped 4" with 3 rows of gunnable sealant.

EAVE TO GABLE TRANSITION

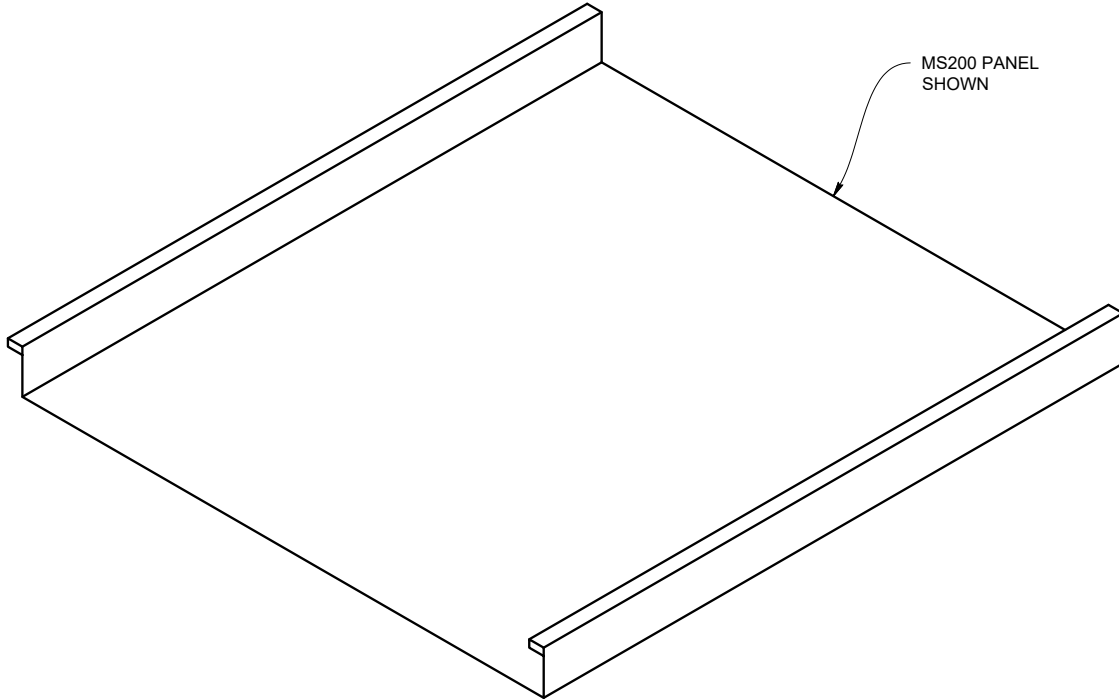

STEP 1

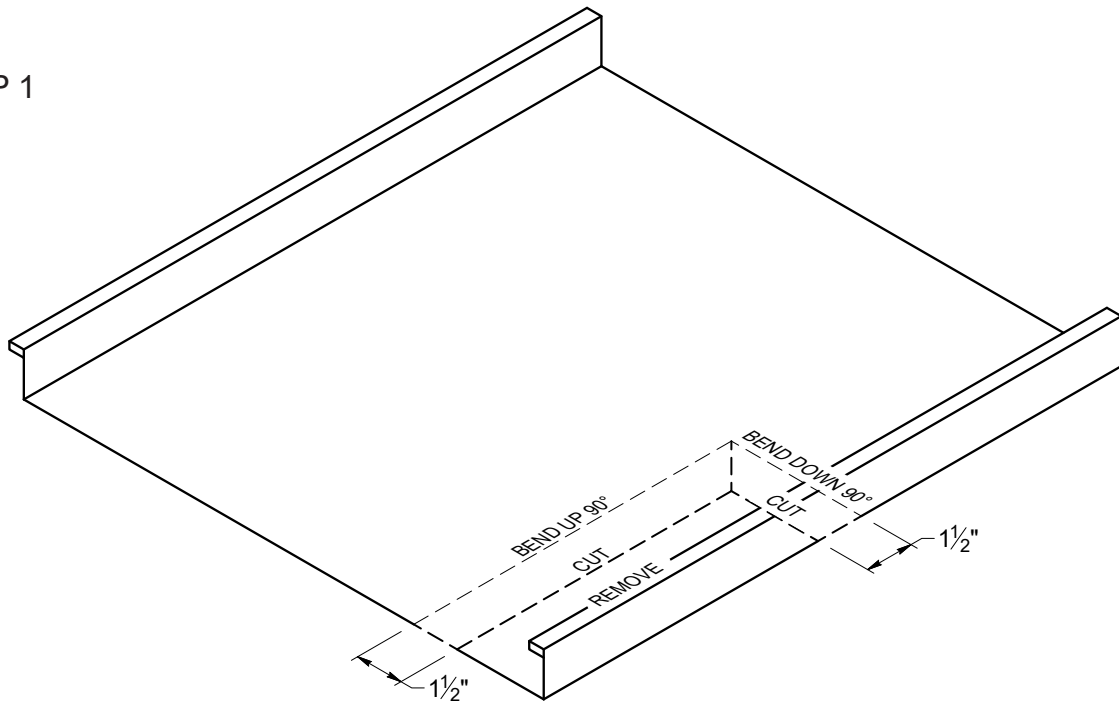

Note: All screws must be fastened into solid substrate.
Flashing must be lapped 4" with 3 rows of gunnable sealant.

Eave to Gable Transition

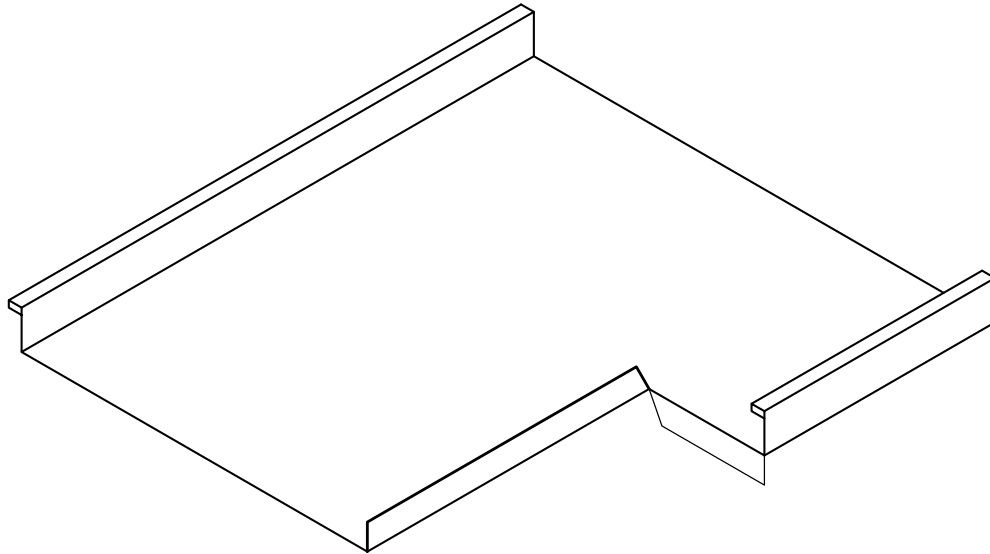

STEP 2

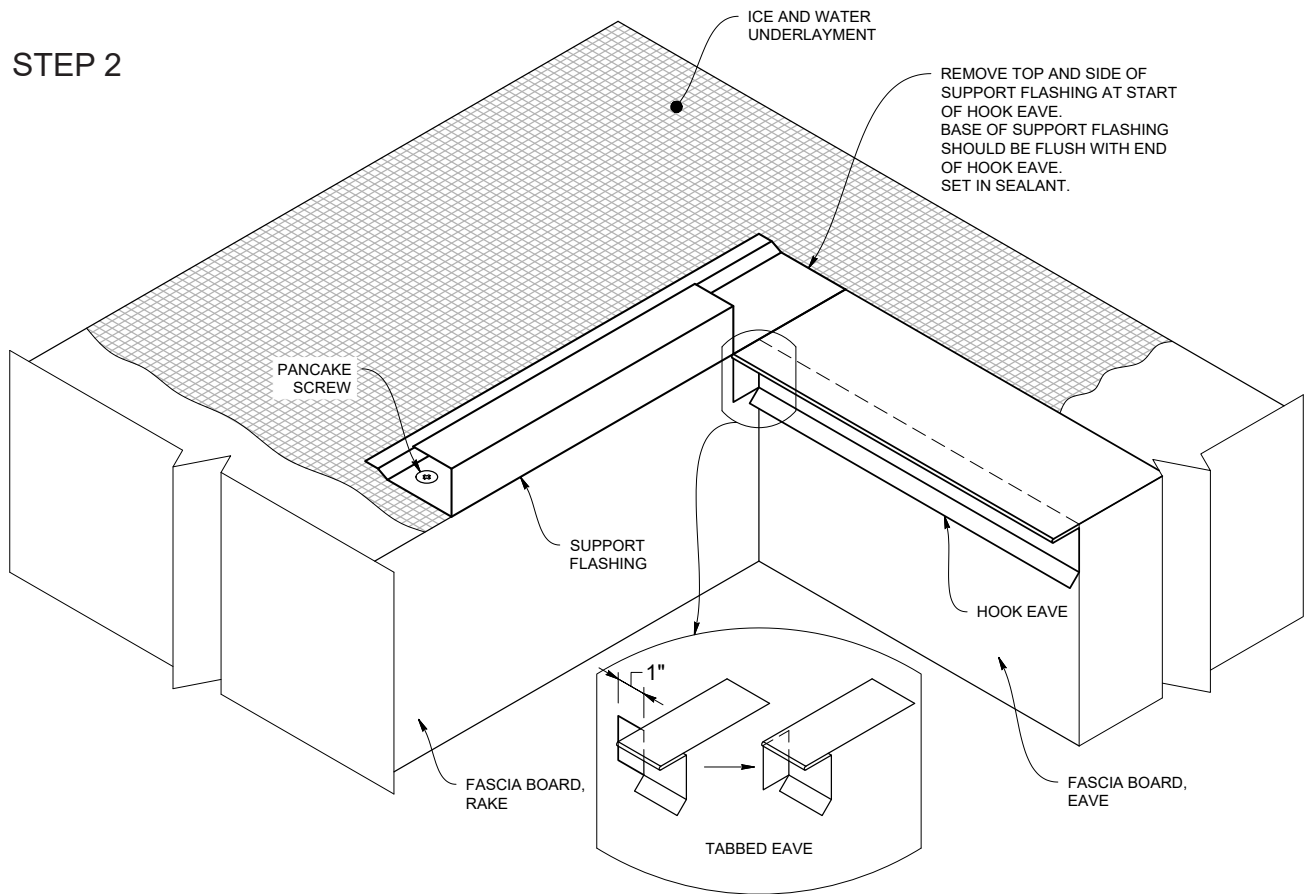

Note: All screws must be fastened into solid substrate.
Flashing must be lapped 4" with 3 rows of gunnable sealant.

Eave to Gable Transition

STEP 3

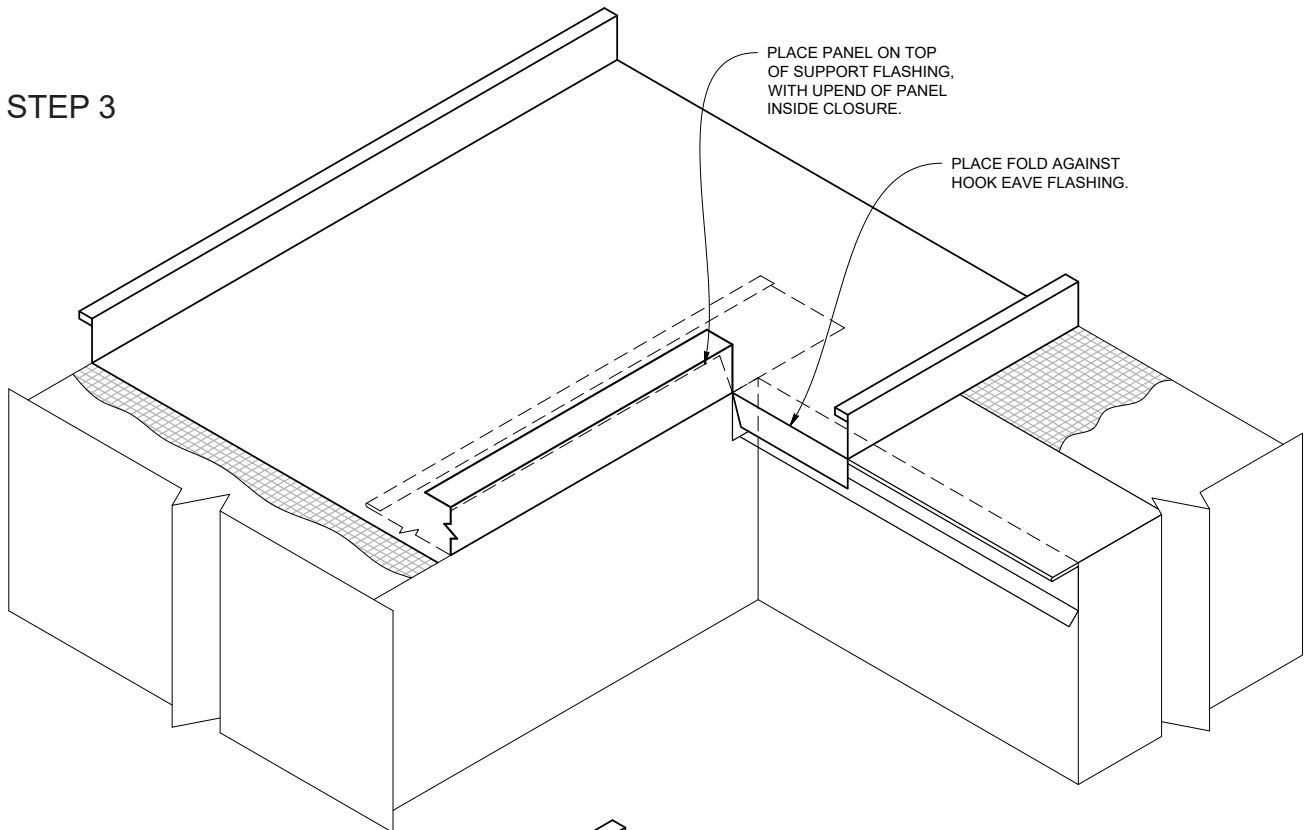

STEP 4

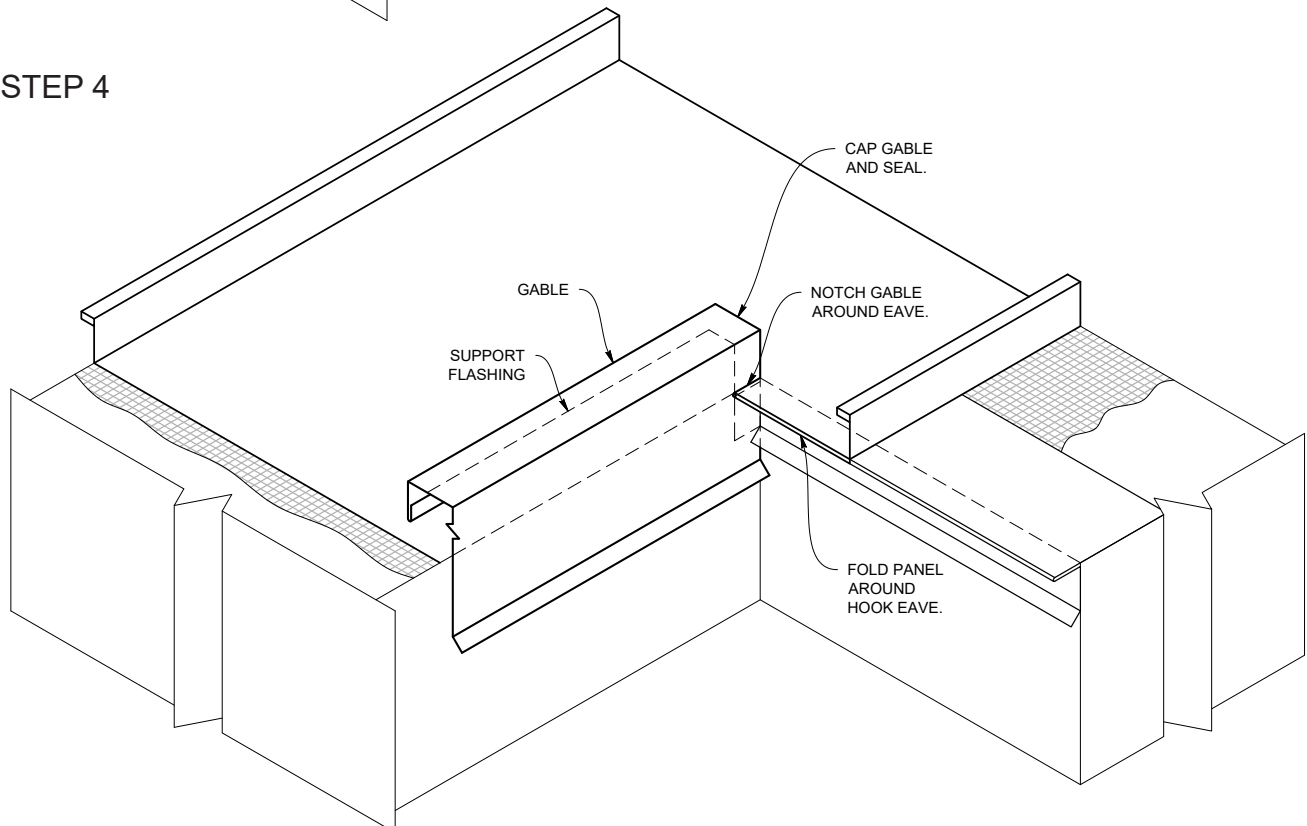

Note: All screws must be fastened into solid substrate.
Flashing must be lapped 4" with 3 rows of gunnable sealant.

Pipe Penetration - on Plate

FOR PIPES LOCATED > 20 FT FROM PIN POINT

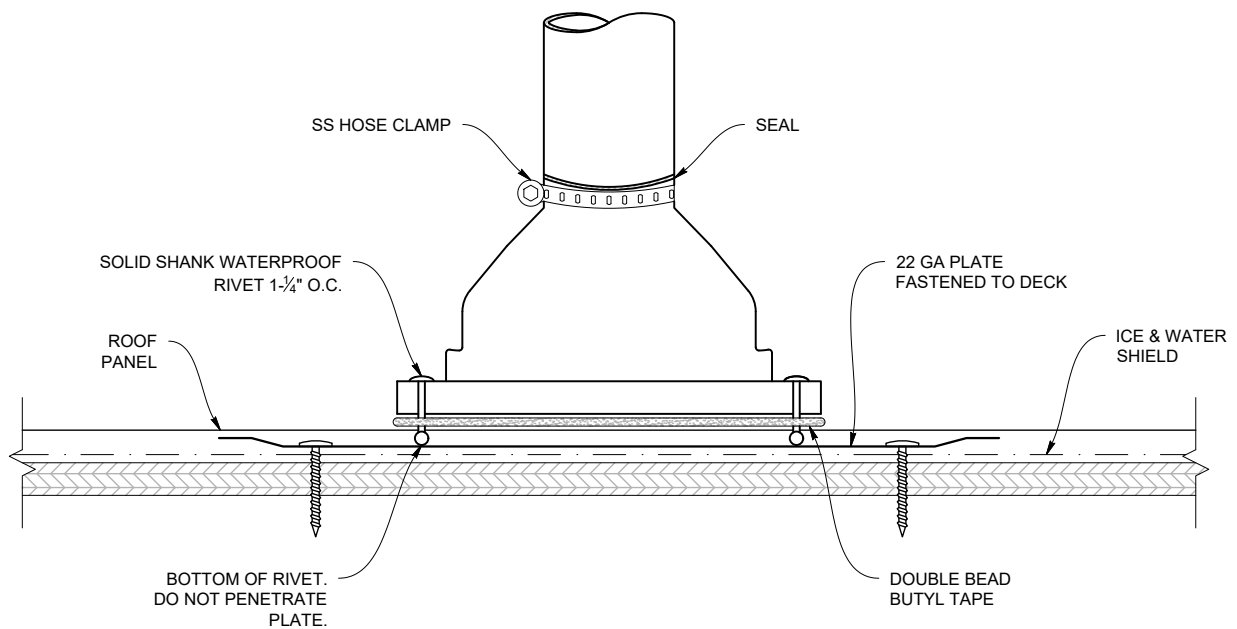

TWO TYPES OF PLATES YOU CAN USE:

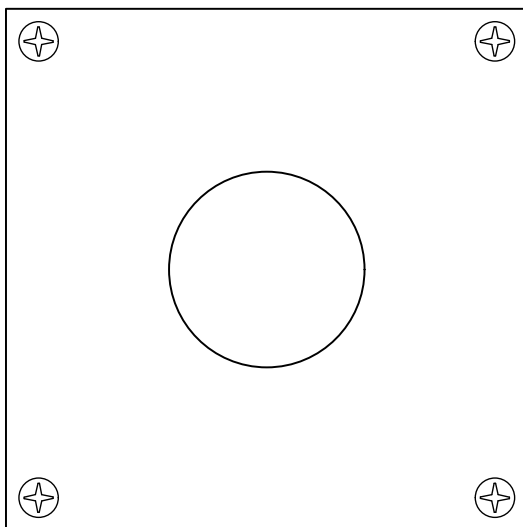

SINGLE PLATE

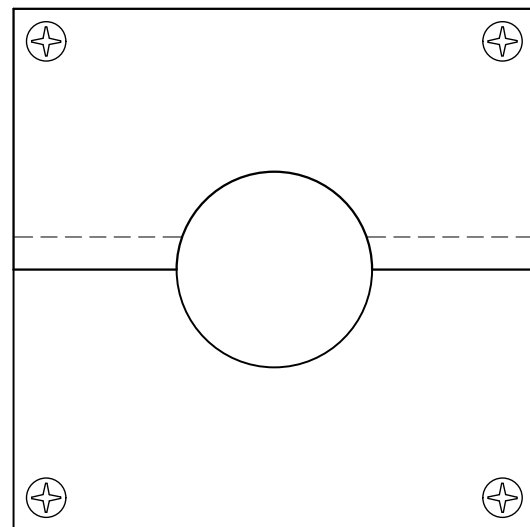

TWO HALF-PLATES

Note: All screws must be fastened into solid substrate.
Flashing must be lapped 4" with 3 rows of gunnable sealant.

Pipe Penetration - on Rib

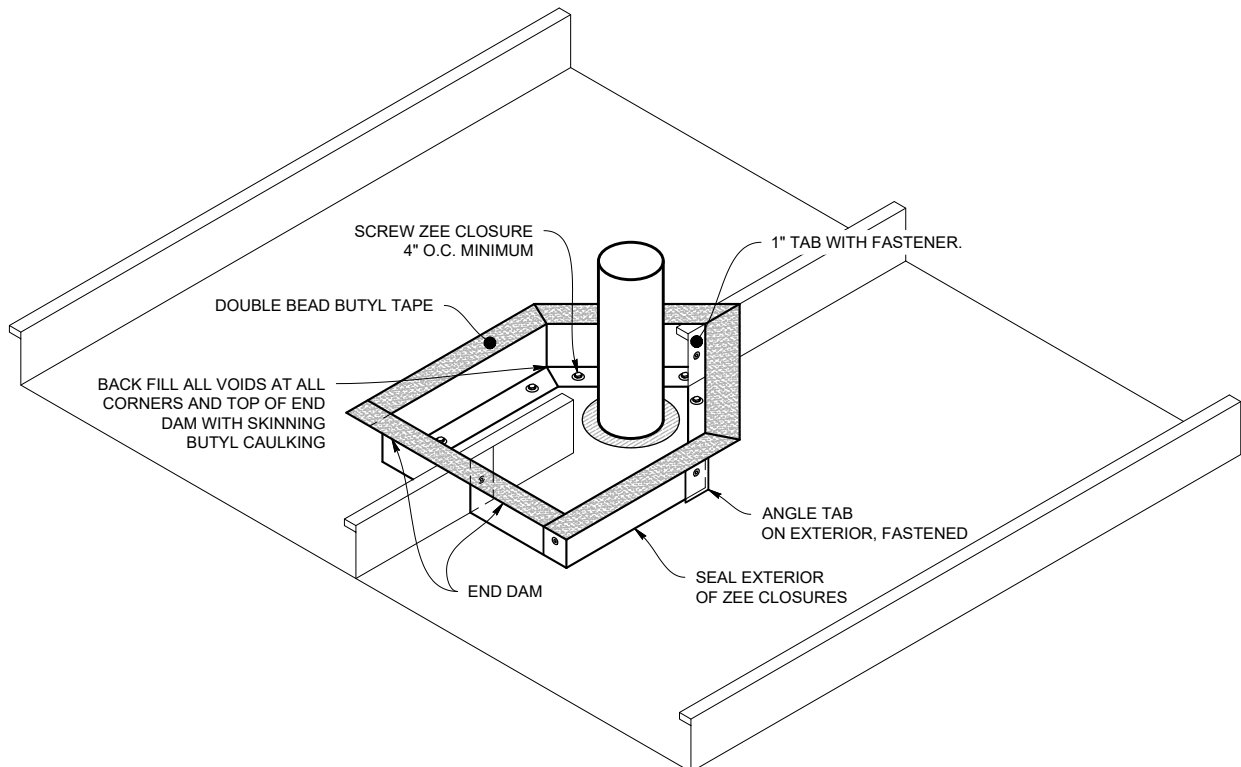
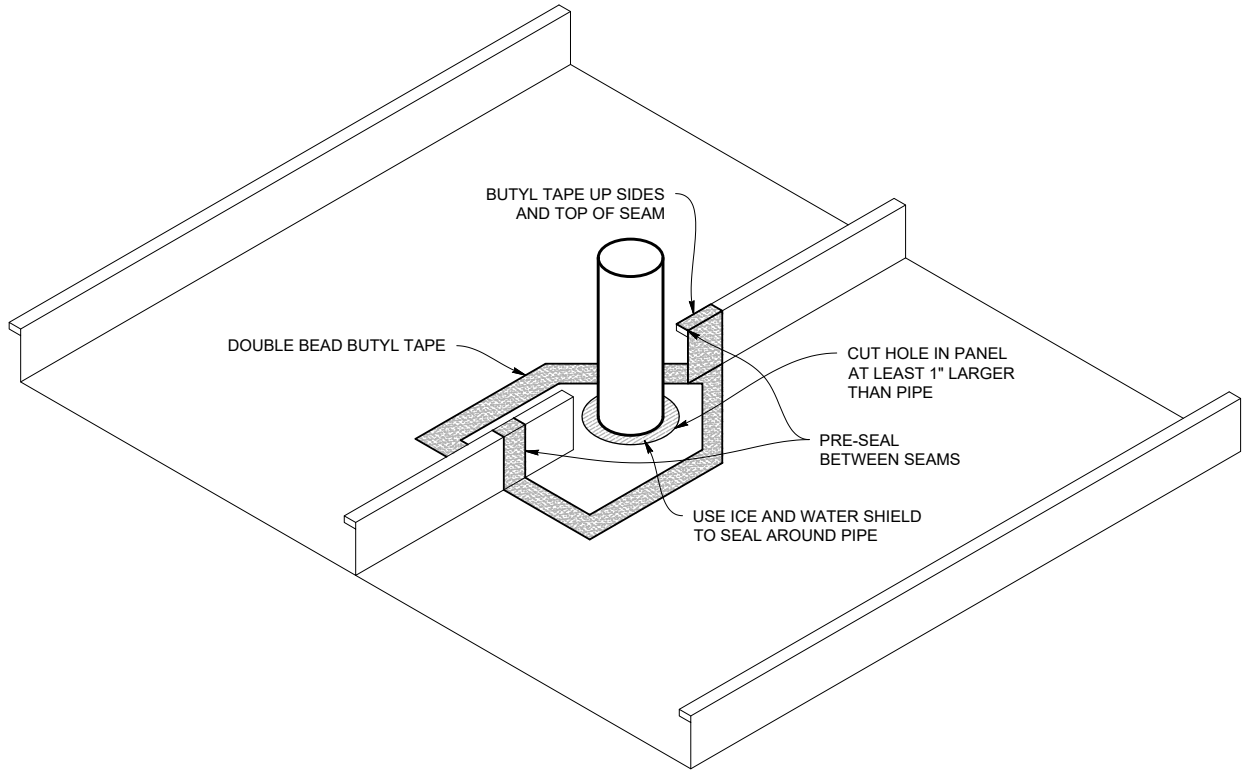

Note: All screws must be fastened into solid substrate.
Flashing must be lapped 4" with 3 rows of gunnable sealant.

Pipe Penetration - on Pan

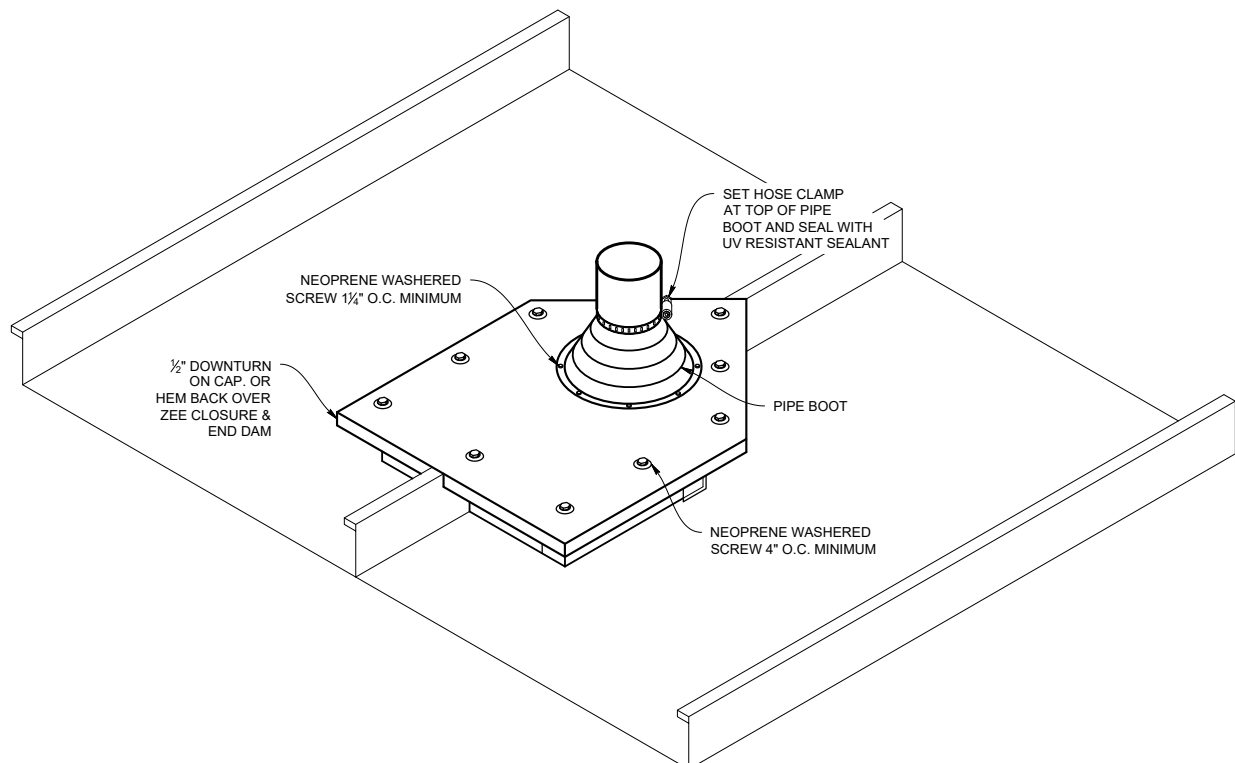
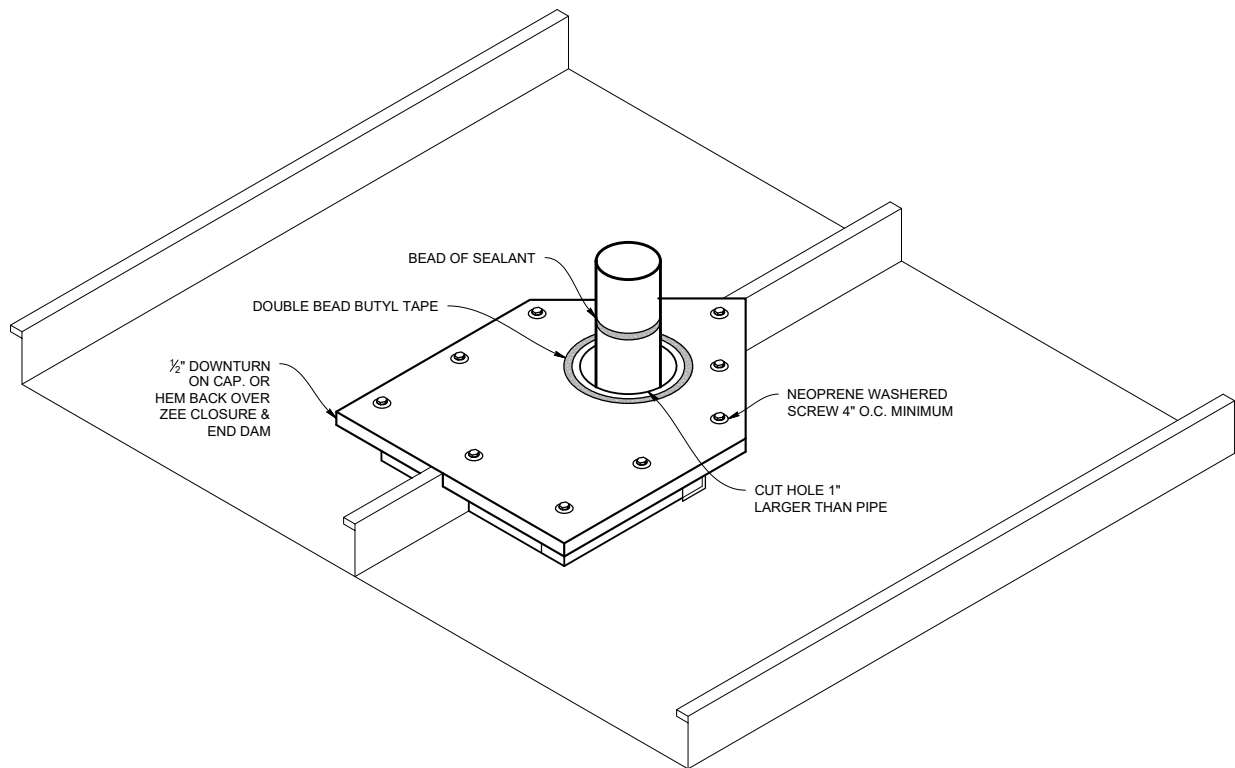

Note: All screws must be fastened into solid substrate.
Flashing must be lapped 4" with 3 rows of gunnable sealant.

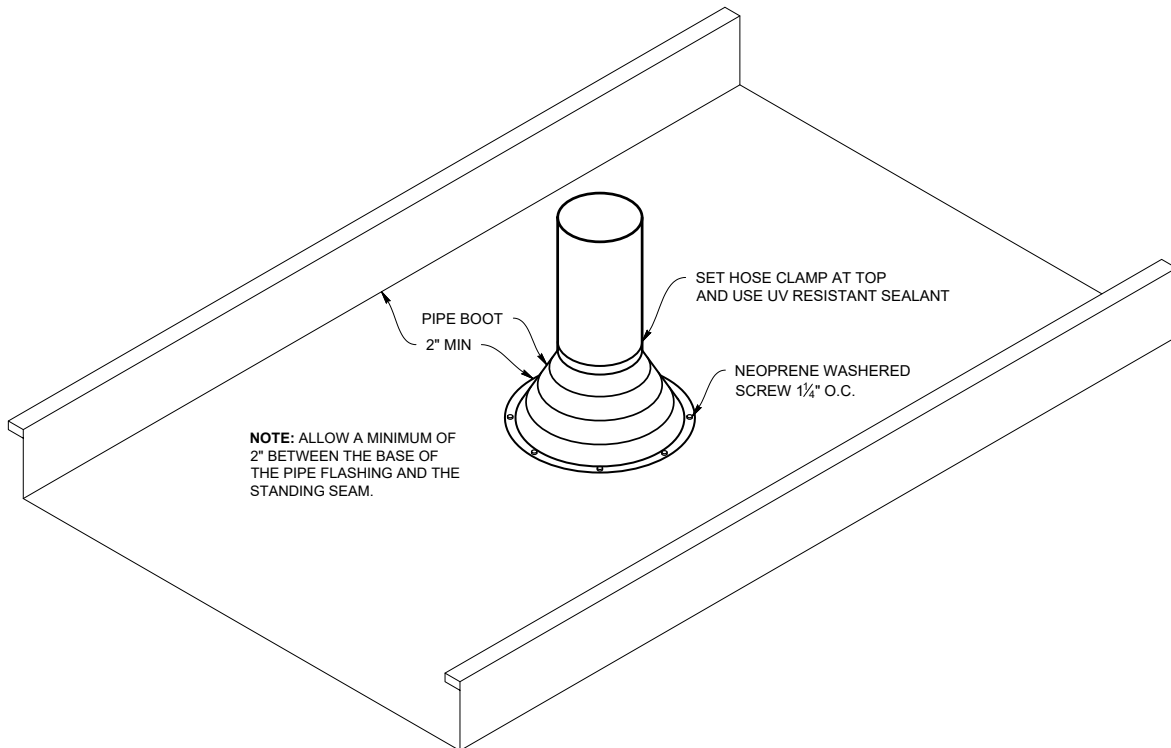
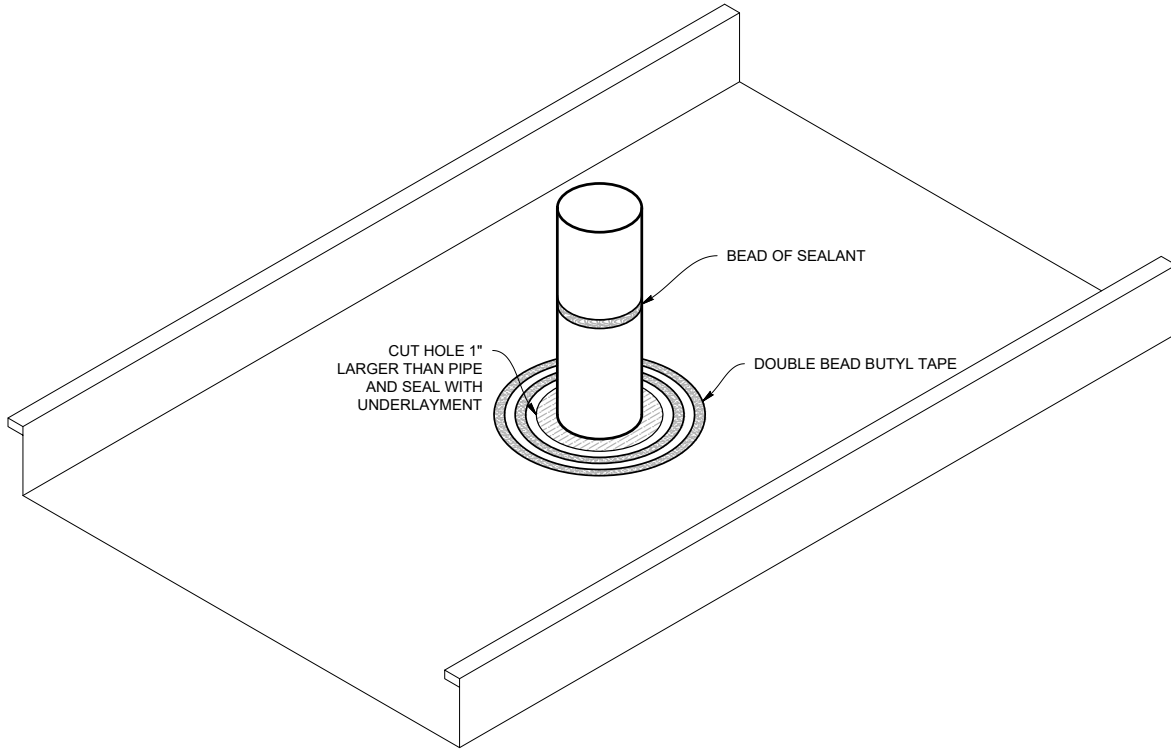

Note: All screws must be fastened into solid substrate.
Flashing must be lapped 4" with 3 rows of gunnable sealant.

MS-200™ - WT

Flashing and Details Selection
Flashing: 10' Standard

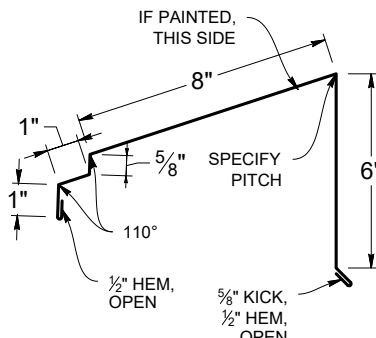
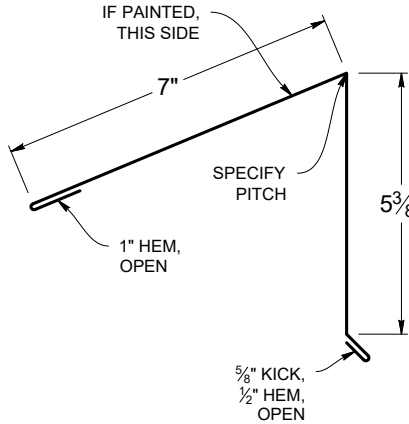
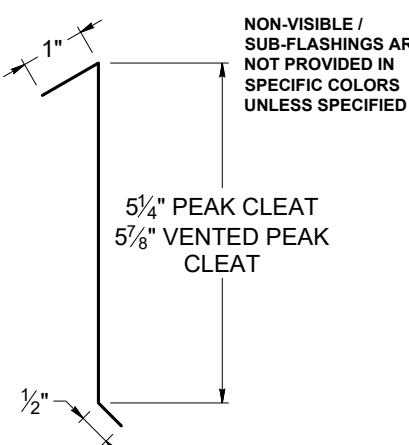
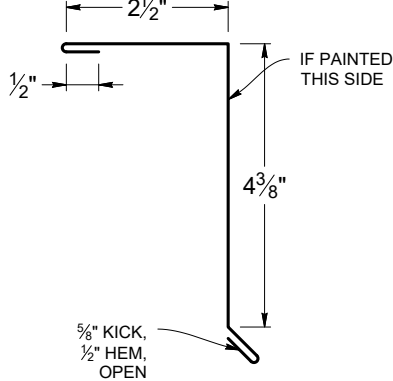
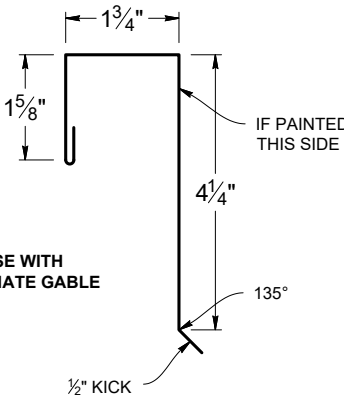
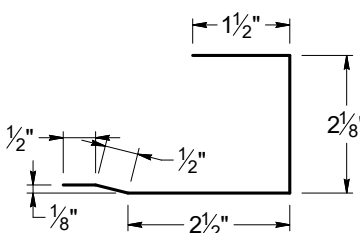
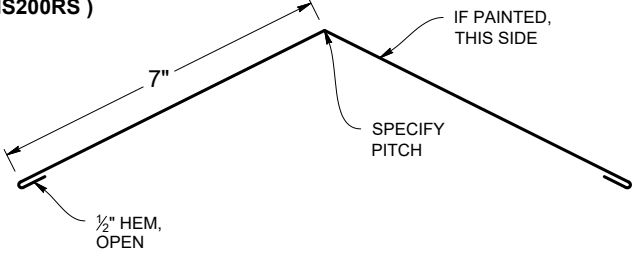
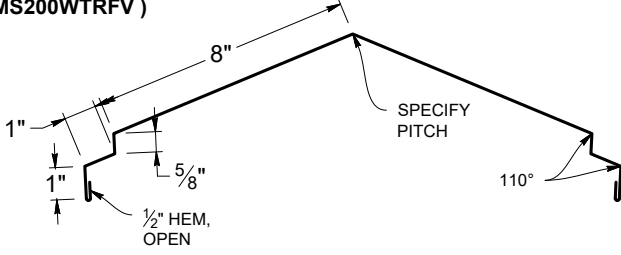

<p>EAVE STANDARD (MS200ES)</p> <p>IF PAINTED, THIS SIDE</p> <p>3 3/8"</p> <p>1 1/2"</p> <p>SPECIFY PITCH</p> <p>5/8" KICK, 1/2" HEM, OPEN</p> <p>SCALE 1:3 S.O. 6" WEIGHT: 4.9 LBS.</p>	<p>EAVE HOOK (MS200EH)</p> <p>IF PAINTED, THIS SIDE</p> <p>4 3/8"</p> <p>1"</p> <p>1 1/2"</p> <p>SPECIFY PITCH</p> <p>5/8" KICK, 1/2" HEM, OPEN</p> <p>SCALE 1:3 S.O. 8" WEIGHT: 6.5 LBS.</p>	<p>OFFSET CLEAT (MS200OC)</p> <p>NON-VISIBLE / SUB-FLASHINGS ARE NOT PROVIDED IN SPECIFIC COLORS UNLESS SPECIFIED</p> <p>1"</p> <p>166°</p> <p>1/2"</p> <p>1/2"</p> <p>SCALE 1:2 S.O. 3" WEIGHT: 2.5 LBS.</p>
<p>GUTTER HANGER (AGH6)</p> <p>NON-VISIBLE / SUB-FLASHINGS ARE NOT PROVIDED IN SPECIFIC COLORS UNLESS SPECIFIED</p> <p>S.O. 8"</p> <p>1"</p> <p>1"</p> <p>6"</p> <p>WEIGHT: 6.5 LBS.</p> <p>SCALE 1:2</p>		
<p>BOX GUTTER (MS200BG)</p> <p>3/4"</p> <p>1"</p> <p>1/2" HEM, OPEN</p> <p>1"</p> <p>3 1/4"</p> <p>2X 108°</p> <p>4"</p> <p>6"</p> <p>5 1/2"</p> <p>IF PAINTED, THIS SIDE</p> <p>SCALE 1:4 S.O. 16" WEIGHT: 13.3 LBS.</p>	<p>GABLE STANDARD (MS200GS)</p> <p>1 3/4"</p> <p>1 5/8"</p> <p>4 3/8"</p> <p>5/8" KICK, 1/2" HEM, OPEN</p> <p>IF PAINTED, THIS SIDE</p> <p>SCALE 1:4 S.O. 9.375" WEIGHT: 7.6 LBS.</p>	<p>GABLE SUPPORT CLEAT (MS200GC)</p> <p>NON-VISIBLE / SUB-FLASHINGS ARE NOT PROVIDED IN SPECIFIC COLORS UNLESS SPECIFIED</p> <p>1"</p> <p>4 1/4"</p> <p>1/2" KICK</p> <p>SCALE 1:3 S.O. 5.75" WEIGHT: 4.7 LBS.</p>

<p>VENTED PEAK FLASHING (MS200RECV)</p>  <p>IF PAINTED, THIS SIDE</p> <p>8"</p> <p>1"</p> <p>5/8"</p> <p>SPECIFY PITCH</p> <p>110°</p> <p>1/2" HEM, OPEN</p> <p>5/8" KICK, 1/2" HEM, OPEN</p> <p>6"</p> <p>SCALE 1:4 S.O. 18.25" WEIGHT: 14.85 LBS.</p>	<p>PEAK FLASHING (MS200REC)</p>  <p>IF PAINTED, THIS SIDE</p> <p>7"</p> <p>SPECIFY PITCH</p> <p>1" HEM, OPEN</p> <p>5/8" KICK, 1/2" HEM, OPEN</p> <p>5 3/8"</p> <p>SCALE 1:4 S.O. 14.5" WEIGHT: 11.9 LBS.</p>	<p>PEAK CLEAT / VENTED PEAK CLEAT (MS200RECC / MS200VRECC)</p>  <p>1"</p> <p>NON-VISIBLE / SUB-FLASHINGS ARE NOT PROVIDED IN SPECIFIC COLORS UNLESS SPECIFIED</p> <p>5 1/4" PEAK CLEAT</p> <p>5 7/8" VENTED PEAK CLEAT</p> <p>1/2"</p> <p>SCALE 1:3 S.O. 6.75"/7.375" WEIGHT: 5.49 LBS.</p>
<p>ALTERNATE GABLE (MS200AT)</p>  <p>2 1/2"</p> <p>1/2"</p> <p>IF PAINTED, THIS SIDE</p> <p>4 3/8"</p> <p>5/8" KICK, 1/2" HEM, OPEN</p> <p>SCALE 1:4 S.O. 8.5" WEIGHT: 7 LBS.</p>	<p>ALTERNATE GABLE CLEAT (MS200AGC)</p>  <p>1 3/4"</p> <p>1 5/8"</p> <p>IF PAINTED, THIS SIDE</p> <p>4 1/4"</p> <p>135°</p> <p>1/2" KICK</p> <p>*FOR USE WITH ALTERNATE GABLE ONLY</p> <p>SCALE 1:3 S.O. 8.625" WEIGHT: 7.02 LBS.</p>	<p>SUPPORT FLASHING (MS200SF)</p>  <p>1 1/2"</p> <p>2 1/8"</p> <p>1/2"</p> <p>1/8"</p> <p>2 1/2"</p> <p>NON-VISIBLE / SUB-FLASHINGS ARE NOT PROVIDED IN SPECIFIC COLORS UNLESS SPECIFIED</p> <p>SCALE 1:3 S.O. 7.125" WEIGHT: 5.8 LBS.</p>
<p>STANDARD RIDGE (MS200RS)</p>  <p>IF PAINTED, THIS SIDE</p> <p>7"</p> <p>SPECIFY PITCH</p> <p>1/2" HEM, OPEN</p> <p>SCALE 1:4 S.O. 15" WEIGHT: 13.1 LBS.</p>	<p>WT RIDGE FULL VENTED (MS200WTRFV)</p>  <p>8"</p> <p>SPECIFY PITCH</p> <p>110°</p> <p>1"</p> <p>5/8"</p> <p>1/2" HEM, OPEN</p> <p>SCALE 1:6 S.O. 22.25" WEIGHT: 18.1 LBS.</p>	

MS-200™ - WT

Flashing and Details Selection
Flashing: 10' Standard

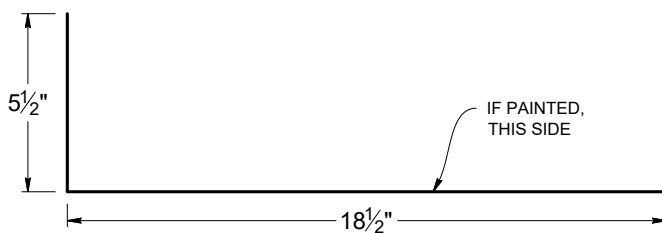
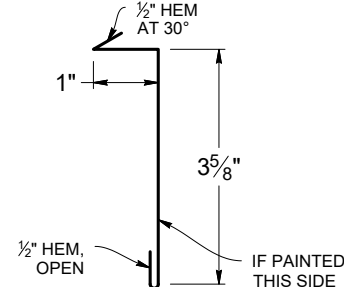

<p>VALLEY WIDE FLASHING (MS200VFW)</p> <p>S.O. 34.5" WEIGHT: 28.2 LBS. SCALE 1:5</p>		
<p>VALLEY FLASHING (MS200VF)</p> <p>SCALE 1:6 S.O. 24" WEIGHT: 19.7 LBS.</p>	<p>OFFSET CLEAT (MS200OC)</p> <p>SCALE 1:2 S.O. 3" WEIGHT: 2.5 LBS.</p>	
<p>CURB SIDEWALL (MS200CSW)</p> <p>SCALE 1:4 S.O. 10.25" WEIGHT: 8.34 LBS.</p>	<p>SIDEWALL (MS200SW)</p> <p>SCALE 1:4 S.O. 8.125" WEIGHT: 6.6 LBS.</p>	
<p>ENDWALL (MS200EW)</p> <p>SCALE 1:4 S.O. 11.5" WEIGHT: 9.8 LBS.</p>	<p>WT VENTED ENDWALL (MS200WTEWW)</p> <p>SCALE 1:4 S.O. 15.5" WEIGHT: 12.6 LBS.</p>	<p>CURB ENDWALL (MS200CH)</p> <p>SCALE 1:4 S.O. 11.5" WEIGHT: 9.8 LBS.</p>

<p>BACK PAN (MS200PAN)</p>  <p>SCALE 1:6 S.O. 24" WEIGHT: 21.3 LBS.</p>	<p>REGLET (MS200RF)</p>  <p>SCALE 1:3 S.O. 5.625" WEIGHT: 4.6 LBS.</p>
---	---

END DAM

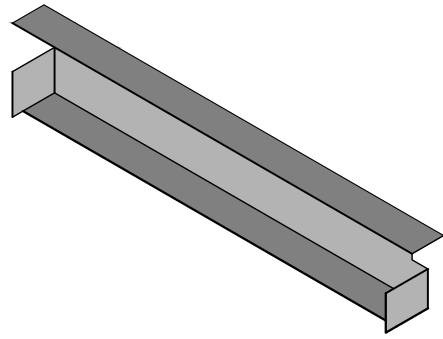

S.O. VARIES

WEIGHT: VARIES

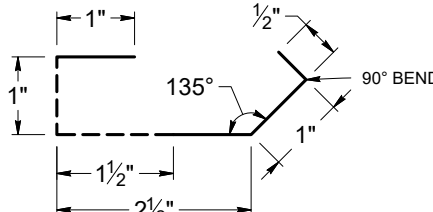
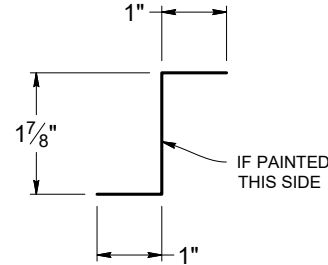
<p>PERFORATED VENT DRIP (MS200PVD)</p> <p>NON-VISIBLE / SUB-FLASHINGS ARE NOT PROVIDED IN SPECIFIC COLORS UNLESS SPECIFIED</p>  <p>SCALE 1:2 S.O. 6" WEIGHT: 4.88 LBS.</p>	<p>ZEE CLOSURE (MS200ZC)</p> <p>NON-VISIBLE / SUB-FLASHINGS ARE NOT PROVIDED IN SPECIFIC COLORS UNLESS SPECIFIED</p>  <p>SCALE 1:3 S.O. 3.875" WEIGHT: 3.15 LBS.</p>
--	--

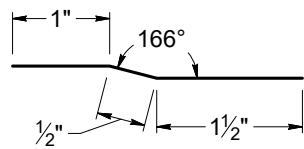
<p>OFFSET CLEAT (MS200OC)</p>  <p>SCALE 1:2 S.O. 3" WEIGHT: 2.5 LBS.</p>	
--	--

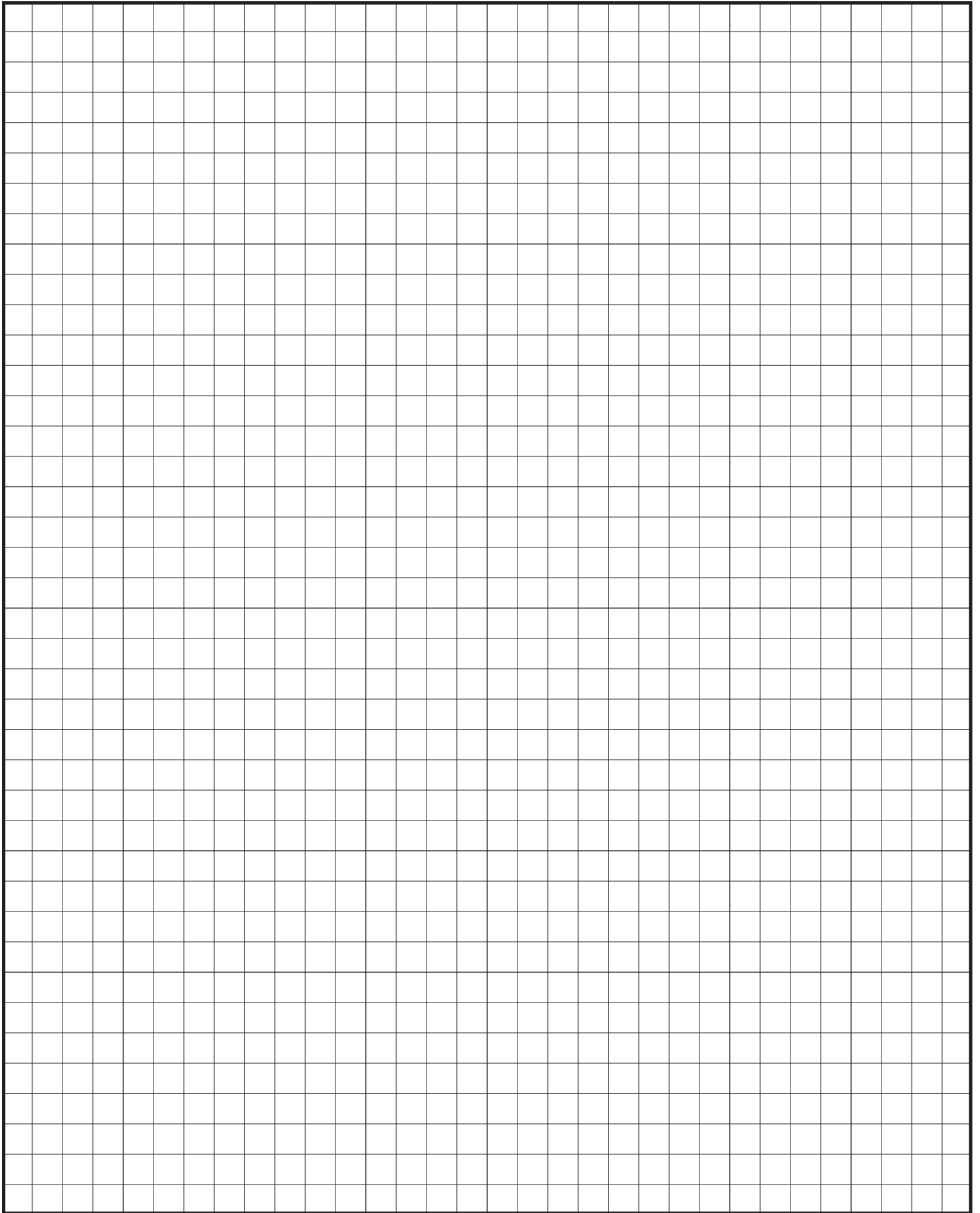



Custom Trim Order

Customer Name: _____ Job Name: _____

Gauge: _____ Color: _____ Status: Original New

Specify: Angles Color Side Dimensions Stretchout

SO _____

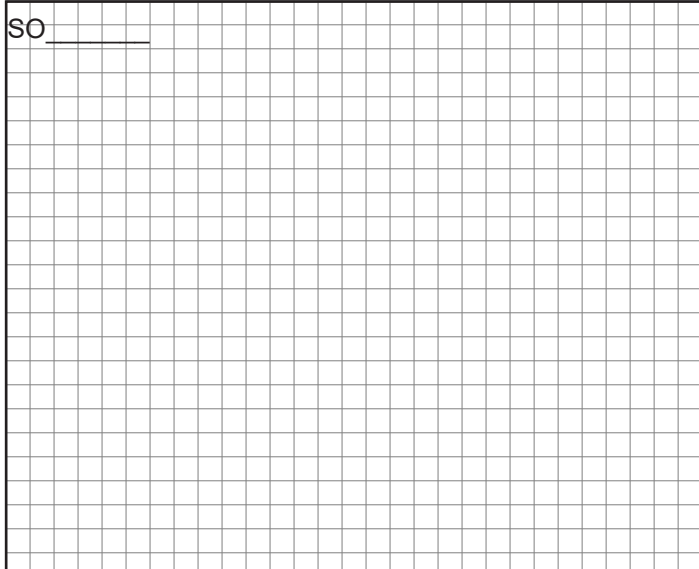

Dwg #: _____ Pitch: _____ # of Pieces: _____

Description: _____

Hems: Open Closed Slightly Open

SO _____

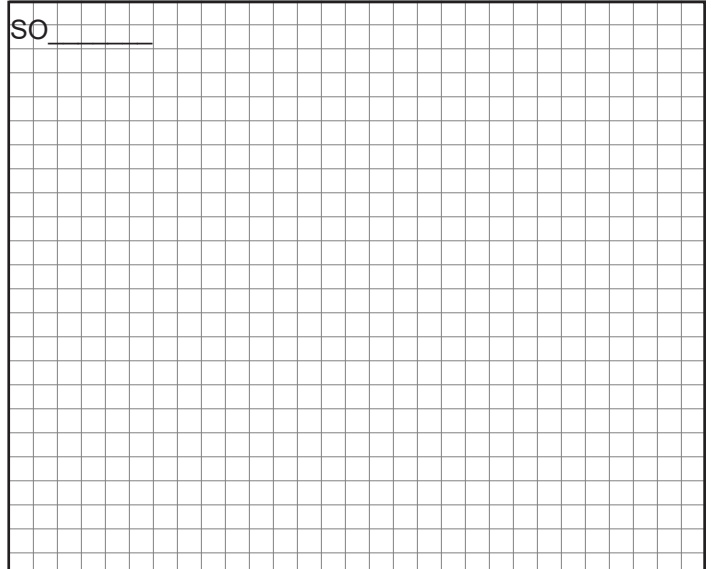

Dwg #: _____ Pitch: _____ # of Pieces: _____

Description: _____

Hems: Open Closed Slightly Open

SO _____

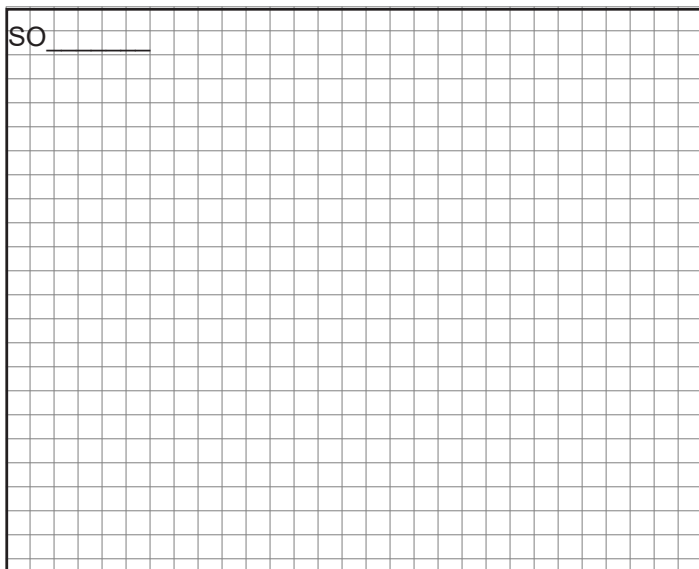

Dwg #: _____ Pitch: _____ # of Pieces: _____

Description: _____

Hems: Open Closed Slightly Open

SO _____

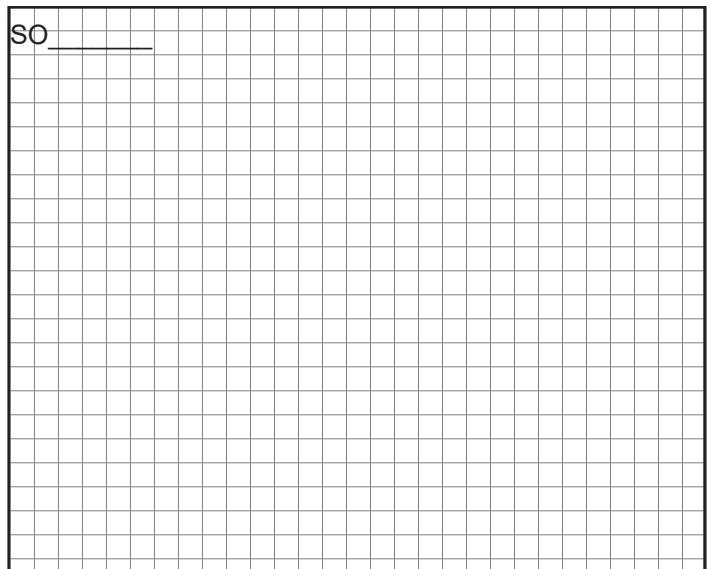

Dwg #: _____ Pitch: _____ # of Pieces: _____

Description: _____

Hems: Open Closed Slightly Open

Please provide a drawing for each flashing with precise measurements and angles
Fax to: 503-581-6877

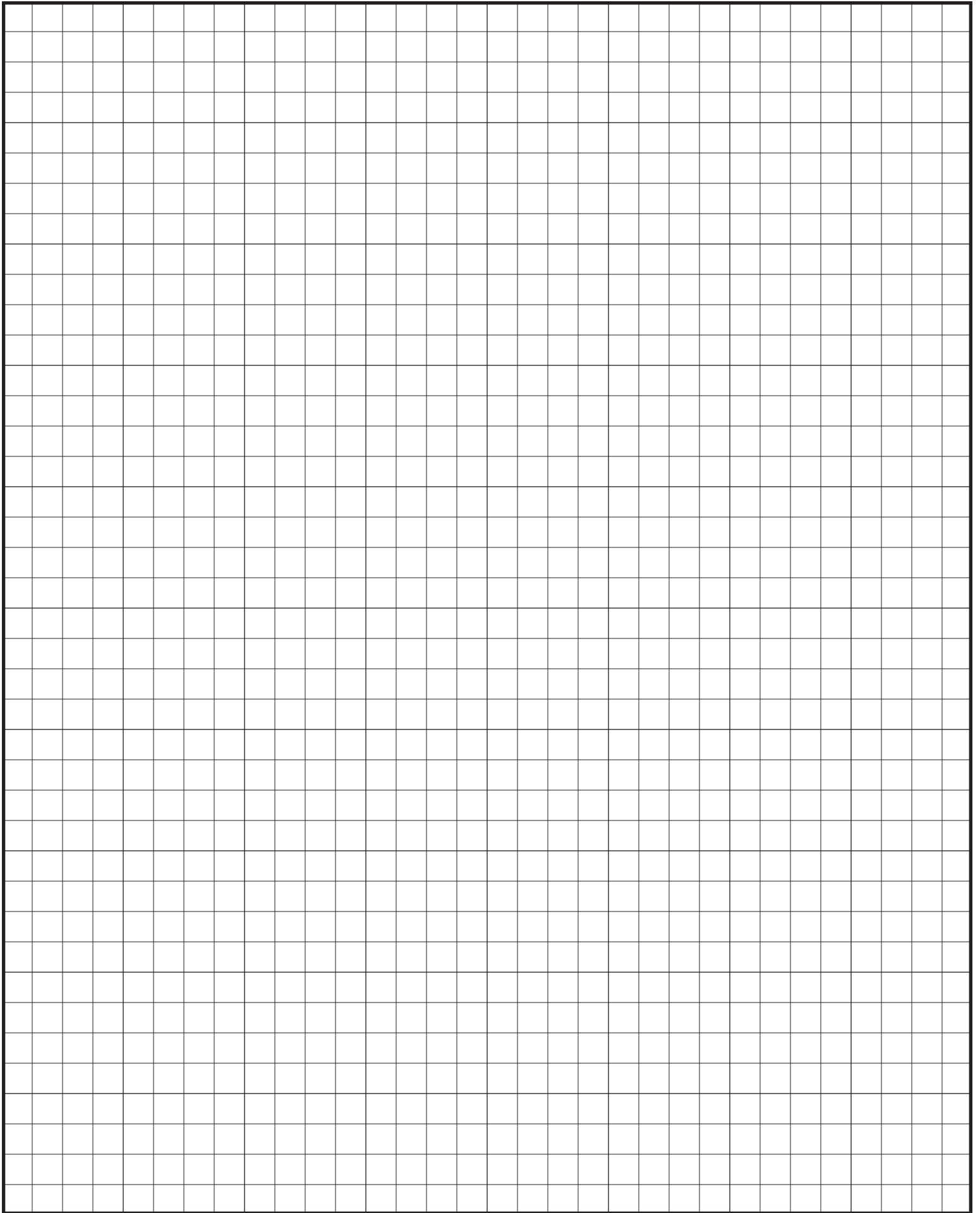



TAYLOR

METAL PRODUCTS

QUALITY PRODUCTS
EXCEPTIONAL SERVICE

SALEM BRANCH

4566 Ridge Dr. NE
Salem, OR 97301

Office: 503-581-8338
Toll Free: 1-800-574-1388
Fax: 503-581-6877

SACRAMENTO BRANCH

3443 Airport Rd,
Sacramento, CA 95834

Office: 916-318-8844
Toll Free: 1-800-574-1388
Fax: 916-993-4123

AUBURN BRANCH

2601 C St. SW
Auburn, WA 98001

Office: 206-900-9923
Toll Free: 1-800-574-1388
Fax: 253-804-3545

RIVERSIDE BRANCH

4880 Felspar St.
Riverside, CA 92509

Office: 323-407-7457
Toll Free: 1-877-504-1594

SPOKANE BRANCH

1010 N Nelson St
Spokane, WA 99202

Office: 509-535-8667
Toll Free: 800-238-4057
Fax: 509-535-8682